

# Laser Safety:

## Hazards, Bioeffects, and Control Measures

Laser Institute of America

Gus Anibarro  
Education Manager

## Laser Safety Overview

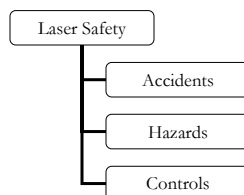

## Laser Accidents & Incidents: Overview from one 1999 Survey

- Top 5 lasers: Nd:YAG, Ar, CO<sub>2</sub>, dye, diode
- Breakdown of incidents
  - 71% - eye injury
  - 11.9% - skin injury
  - 16.9% - non-beam incident

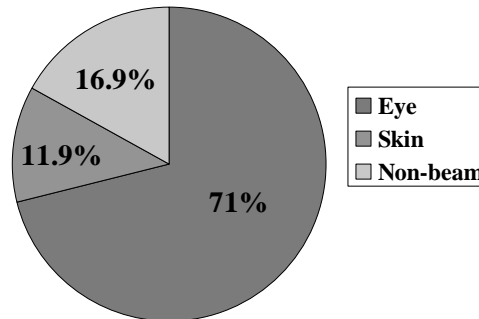

Data from Rockwell, RJ, ILSC 99 Proceedings, LIA

## Laser Accidents: Personnel Exposure Summary

**Accident Data Summary: Division of 395 events: 1964-1998**

Technicians Exposed (81):	20.5%
Scientists Exposed (78):	19.8%
Students Exposed (46):	11.6%
Patients Exposed (40):	10.1%
Plant Workers Exposed (35):	8.9%
Dr.s & Nurses Exposed (26):	6.6%
Pilots & Military Exposed (26):	6.6%
Spectators Exposed (25):	6.3%
Laser Show Operators Exposed (11):	2.8%
Equipment only damaged (10):	2.5%
Field Service Exposed (10):	2.5%
Office Staff (uninvolved) (7):	1.8%

Data from Rockwell, RJ, ILSC 99 Proceedings, LIA

# Laser Accidents

## Eye Injury

>70% of all incidents

Retinal hemorrhage from Q-switched laser pulse.

Visual Effect: Blind spot in field of vision.



Laser Safety © Laser Institute of America

5

## Laser Accidents: Research & Development Laboratory

- Most eye injuries have occurred in research and engineering laboratories. Why?
- Open beams
  - During alignment
  - For flexibility in calibration procedures
  - Experimental changes in setup
- “I know where the beam is!” (Famous last words)



Laser Safety © Laser Institute of America

6

## Many laboratory accidents result from unexpected upward reflections

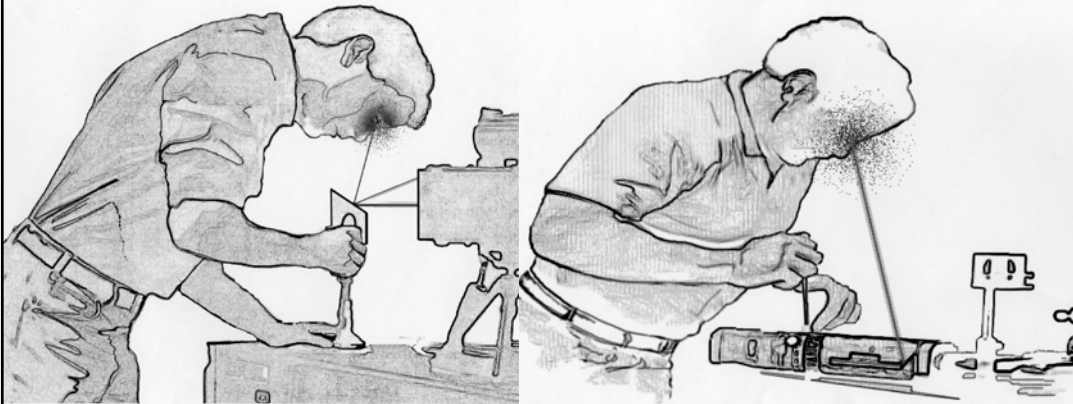

Turning Prism Secondary Reflection

Brewster Window Reflection

Laser Safety © Laser Institute of America

From Sloney, DH, *Optics and Photonics News*, pp 31-37 (1997)

7

## Laser Accidents

- Cause of accidents
  - Not using eyewear (may have been available)
  - Incorrect eyewear selection and/or eyewear failure.
  - Improper fit

Laser Safety © Laser Institute of America

8

## Laser Accidents: *Most Hazardous Acts – Beam Alignment*

- Estimates
  - ~1/3 of all (known) accidents
  - ~60-70% of all (known) laboratory accidents
- Common scenario: unanticipated reflection from an optic while not wearing protective eyewear



Laser Safety © Laser Institute of America

9

## Laser Accidents: *Most Hazardous Acts – Beam Alignment*

- Optics or devices involved in reflections of errant / stray beams:
  - Prisms, Brewster windows, frequency doubling crystals, blade, color center crystal, chrome objective, polarizers, dye cell windows
  - Targets: chalk, photographic paper, test paper
  - Energy meter detector window

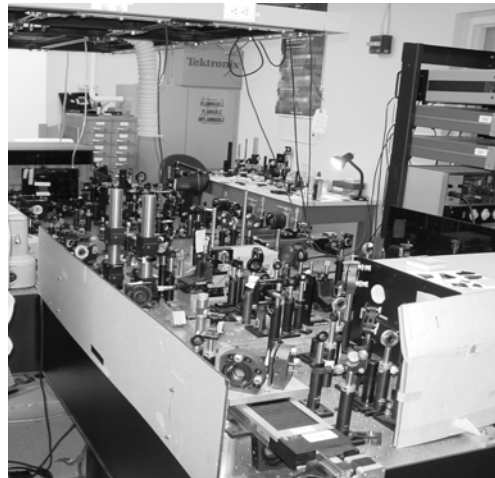

Laser Safety © Laser Institute of America

10

## Laser Accidents: *Most Hazardous Acts – Beam Alignment*

- Not wearing any protective eyewear
- Wearing inappropriate eyewear
  - Wrong OD
  - Wearing low-OD alignment eyewear with operational power levels
  - Wearing high-OD operational eyewear with low-power (alignment) power levels
- Wavelength compatibility problem, especially for multiple wavelengths

## Laser Accidents: *Incident at DOE Laboratory*

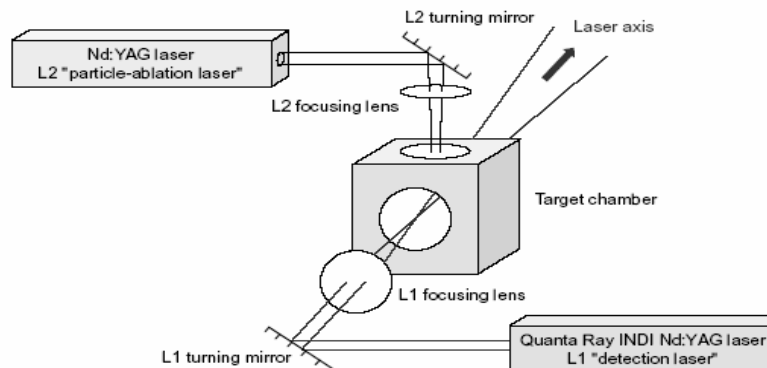
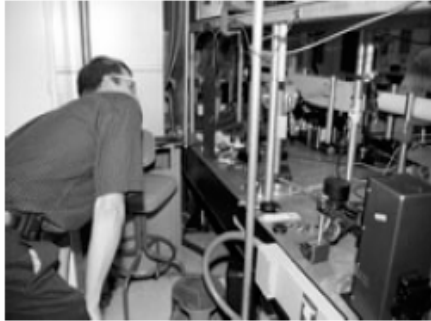

Figure 2.6. A diagram of the experimental system setup, showing the beam path along the L1 axis, through the target chamber, and out the chamber's rear window.

## Laser Accidents: *Incident at DOE Laboratory*



*Figure 2.10. A team member demonstrates S1's position when she looked into the target chamber on July 14.*



*Figure 3.1. IR image of the transmitted laser pulse image on the back wall.*

## Laser Accidents: *Incident at DOE Laboratory*

- 4 primary common causes identified
  - Weaknesses in training and a lack of compliance with accepted national standards
  - Lack of authority of the LSO
  - Inadequate line management oversight of laser operations
  - Lack of enforcement of the PPE requirement
    - Failure to wear laser eye protection

# Learning from Laser Accidents

- In most cases, there is a heightened interest in laser safety after a colleague is injured....
- But not always...

## DOCTOR FUN

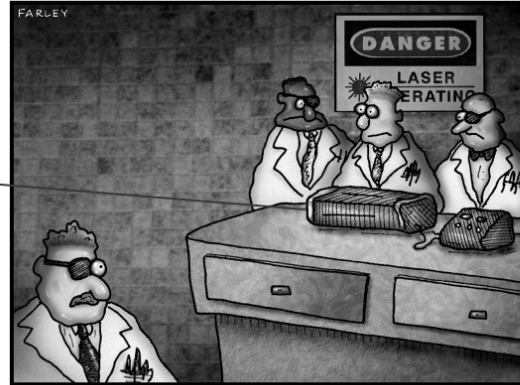

Peer pressure in the laser lab

# Laser Hazards Breakdown

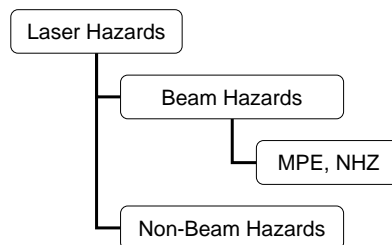

## Beam Hazards: Optical Concentration by the Eye

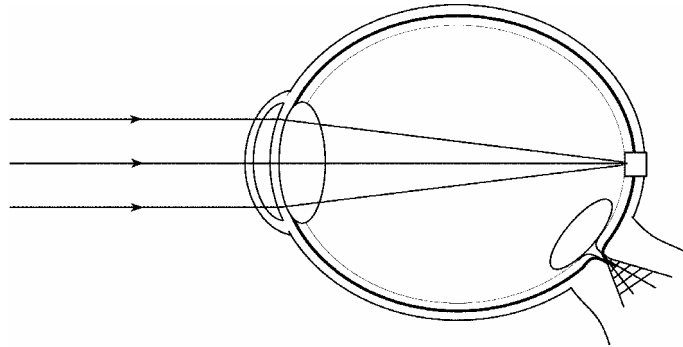

- For wavelengths that reach the retina (400-1400 nm, “the Retinal Hazard Region”), the optical concentration is  $\sim 100,000$  times
- An initial irradiance of  $1 \text{ W/cm}^2$ , becomes  $100 \text{ kW/cm}^2$  at retina!

Laser Safety © Laser Institute of America

17

## Eye Anatomy

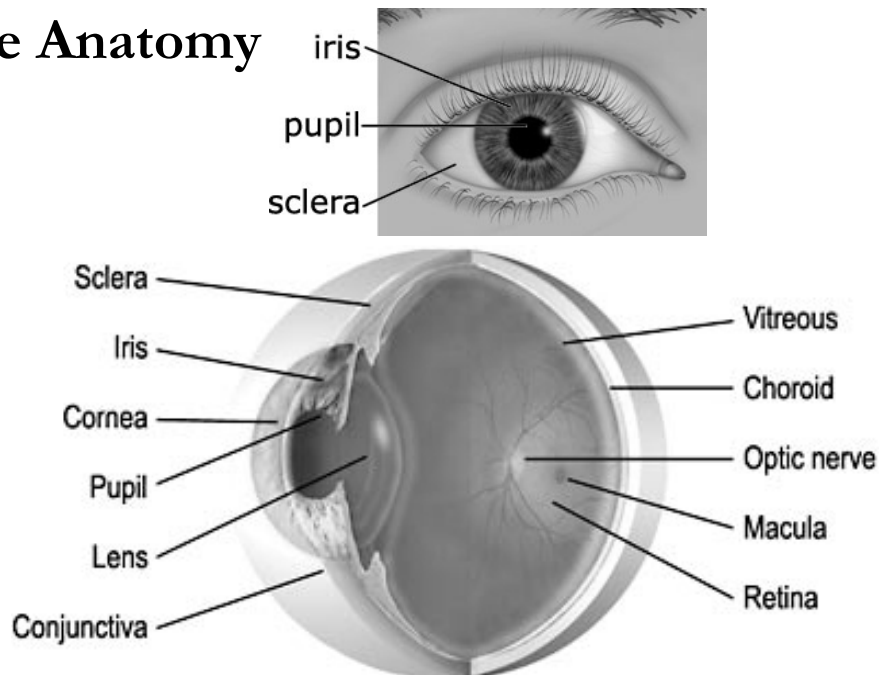

Laser Safety Training © Laser Institute of America

18

## Ocular Absorption Site vs. Wavelength: *UV-B, UV-C, IR-B and IR-C*

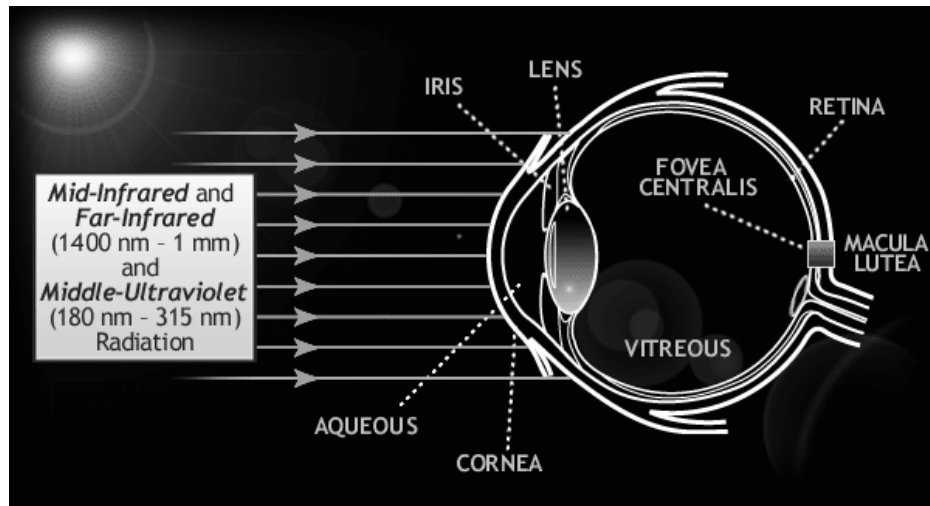

Laser Safety © Laser Institute of America

19

## Beam Hazards

### *Corneal Thermal Burns*

Corneal Thermal Injury -  
Produced by IR-B and  
IR-C radiation.

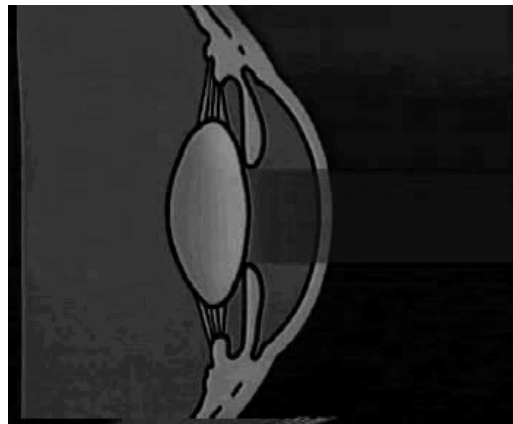

Laser Safety © Laser Institute of America

20

## Beam Hazards

### *Corneal Thermal Burn*

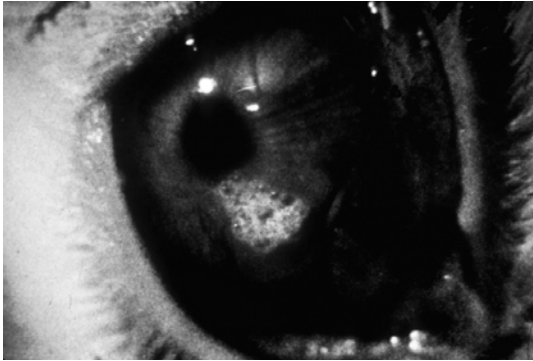

Superficial Injury -  
Epithelium repairs itself  
quickly and lesion clears  
within one or two days.

## Beam Hazards

### *Corneal Thermal Burn*

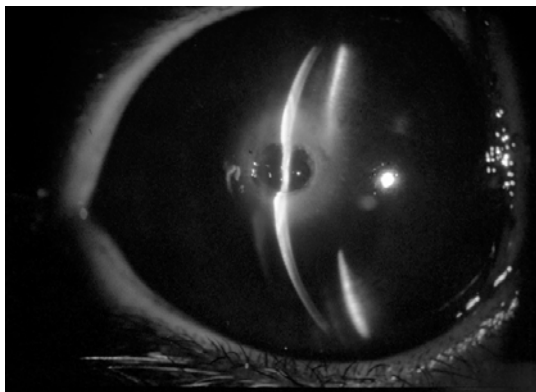

Deep Burns - Penetrating  
burns produce a permanent  
opacity and may require  
corneal transplant for repair.

## Ocular Absorption Site vs. Wavelength: UV-A

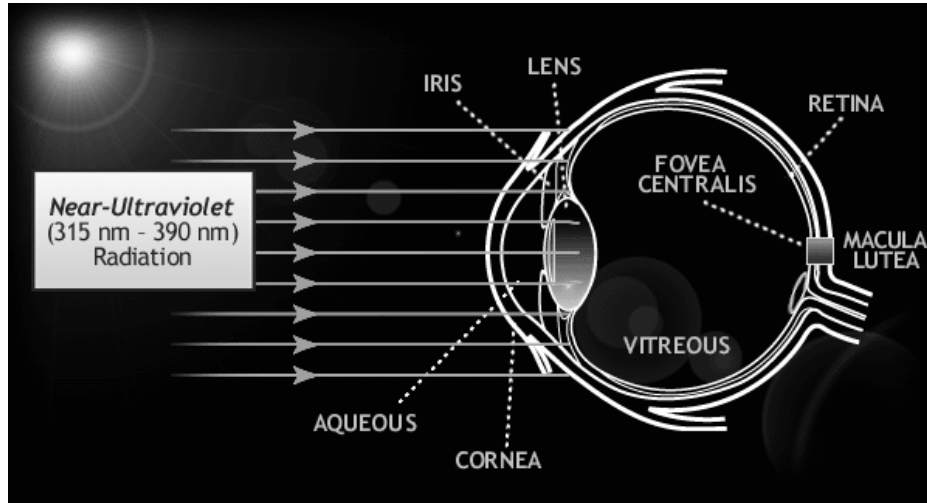

Laser Safety © Laser Institute of America

23

## The Lens

- Lens - Provides accommodation, the ability to focus on near objects;
- very slow metabolic rate and limited ability to repair injury;
- becomes less pliable with age, resulting in presbyopia;
- becomes cloudier with age and eventually opacifies, i.e., a cataract is formed.

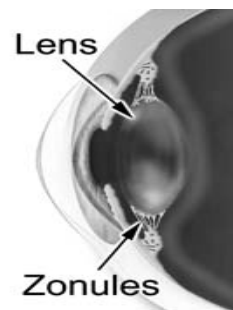

Laser Safety © Laser Institute of America

24

## Cataract

*Opacification of the Lens*  
- clouding of the lens

- Ultraviolet Action Spectrum - Ultraviolet at 300 nm (UV-B).
- Infrared (770-3000nm)
- Cataract - Industrial heat cataract common in glassblowers and foundry men at turn-of-the-century.
- Requires many years of exposure to excessive infrared radiant energy.

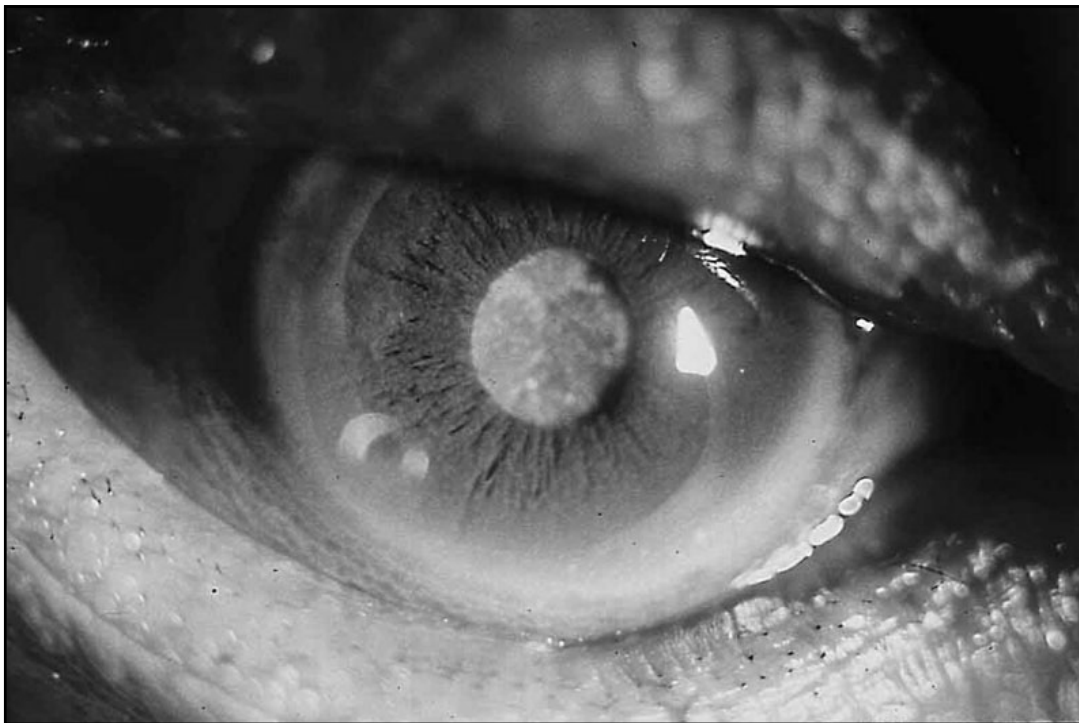
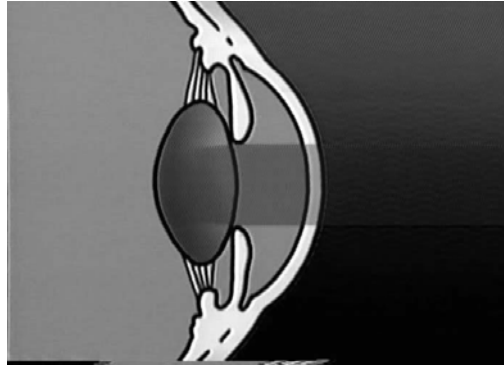

## Ocular Absorption Site vs. Wavelength: the retinal-hazard region, Visible and IR-A (400-1400 nm)

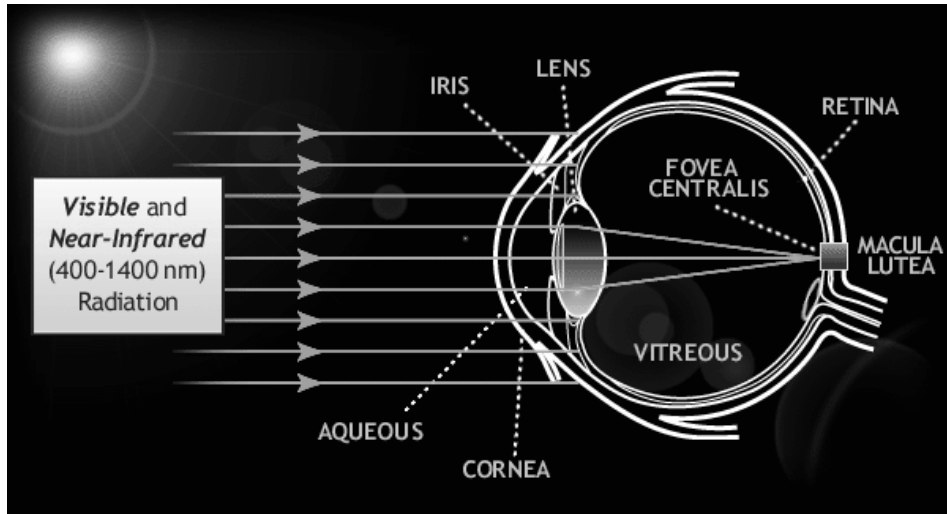

Laser Safety © Laser Institute of America

27

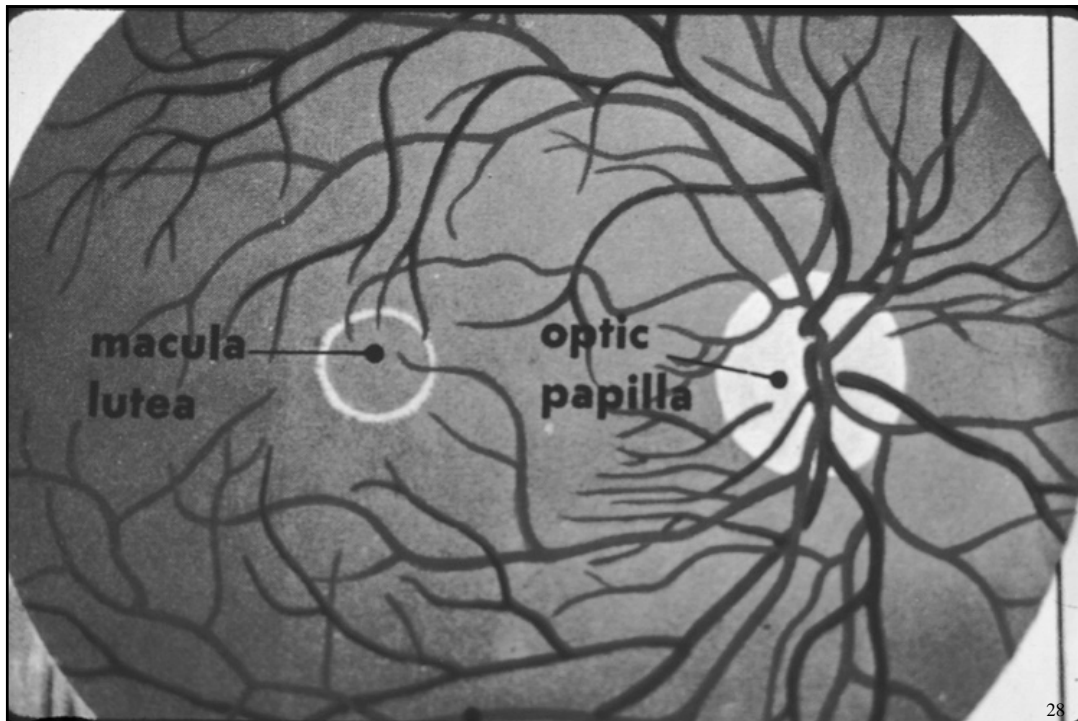

28

# Beam Hazards

## The Retina

- Macula Lutea - (“yellow spot”) where visual acuity is highest and color vision is best.
- Fovea Centralis - Central-most area of macula. Highest concentration of cones. Night blind in this area. Line of optic axis.
- Peripheral Retina - High concentration of rods; region sensitive to movement detection.

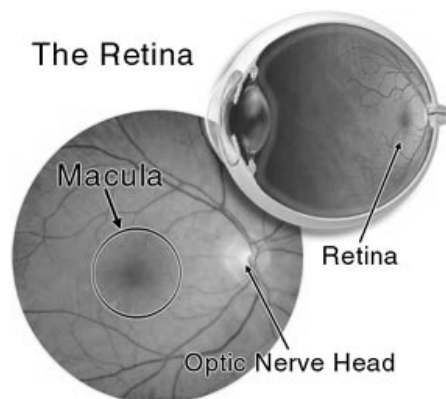

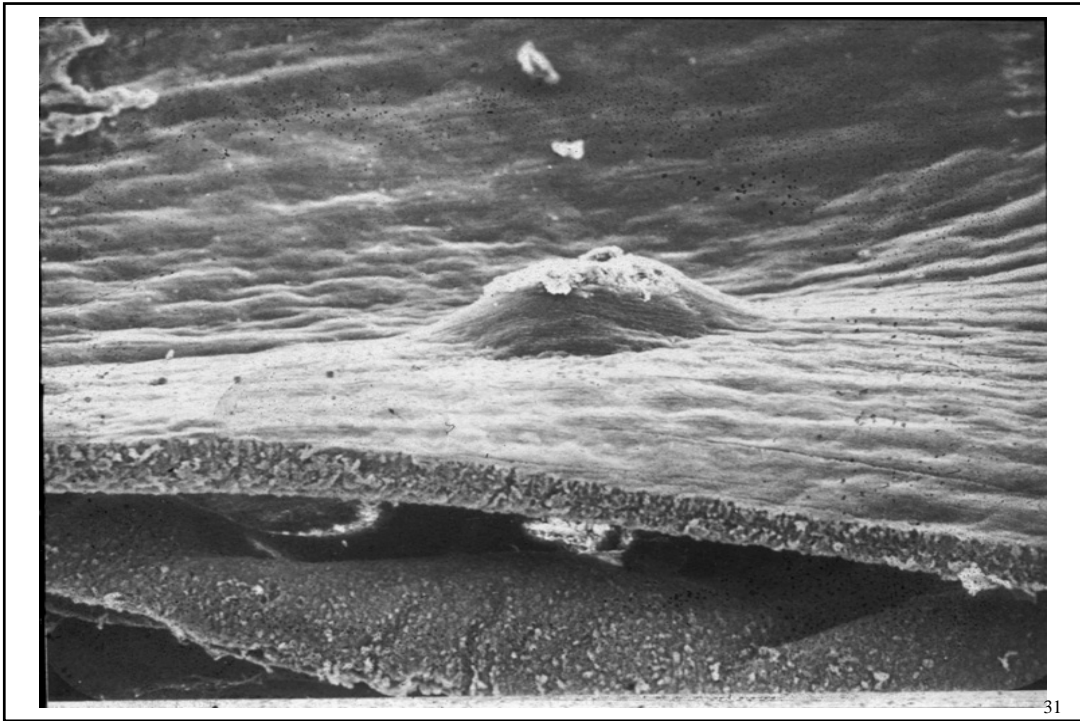

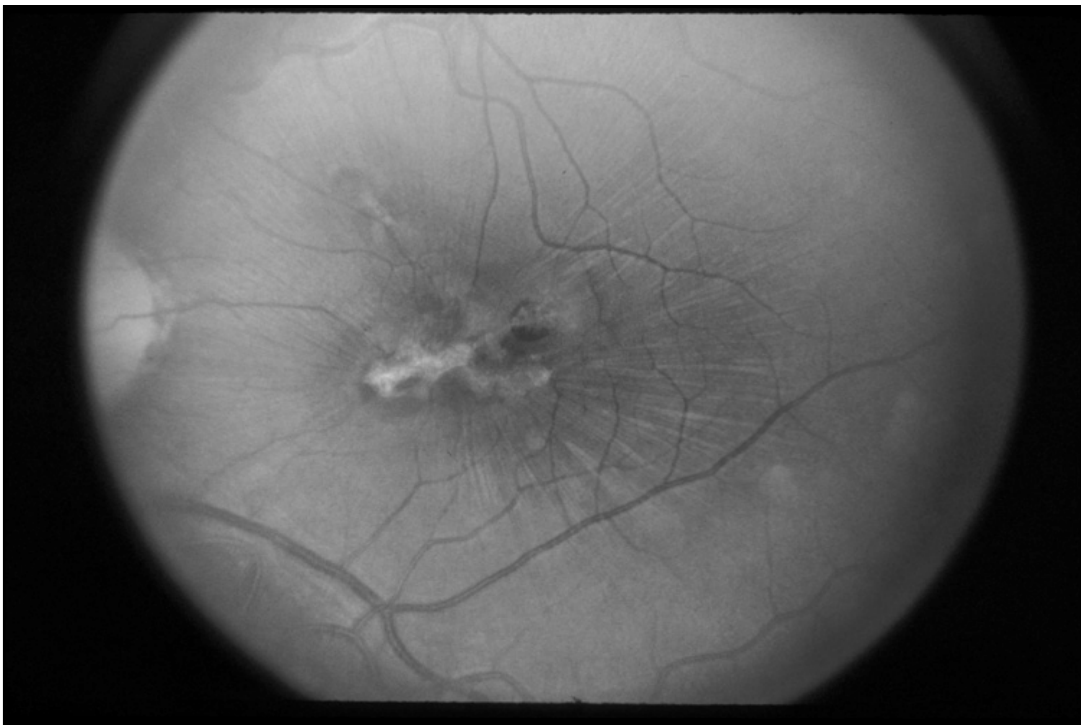

## Beam Hazards

### Maximum Permissible Exposure (MPE)

#### ■ Definition

- Maximum level of exposure to laser radiation without hazardous effect or adverse biological changes in the eye or skin

#### ■ Used to determine

- Nominal hazard zone (NHZ)
- Optical density (OD)
- Accessible Emission Limit (AEL)



## Beam Hazards

### Maximum Permissible Exposure (MPE)



- MPEs are generally found in Table 5a, page 74 of ANSI Z136.1 (2007).
- MPEs for skin exposures are found in Table 7, page 77 of ANSI Z136.1 (2007).

## Maximum Permissible Exposure (MPE) Summary of Five MPE Examples for CW Lasers

Laser Type	Eye or Skin MPE	MPE [W/cm <sup>2</sup> ]	Exposure Duration
CO <sub>2</sub>	Eye	0.100	10 s or longer
Visible	Eye	0.00255	0.25 s
Nd:YAG	Eye	0.0050	10 s or longer
CO <sub>2</sub>	Skin	0.100	10 s or longer
Nd:YAG	Skin	1.00	10 s or longer

## Beam Hazards The Nominal Hazard Zone (NHZ)

- The NHZ is the space within which the level of direct, reflected or scattered laser light exceeds the MPE level for the laser.

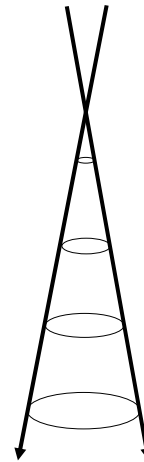

## The Nominal Hazard Zone, NHZ: Laser Criteria Used for NHZ Calculations

Laser Parameter	Nd:YAG	CO <sub>2</sub>	Argon
Wavelength, $\lambda$ , ( $\mu\text{m}$ )	1.064	10.6	0.514
Beam Power, $\Phi$ , (W)	100	500	5.0
Beam Divergence, $\phi$ , (mrad)	2.0	2.0	1.0
Beam Size at Aperture, a, (mm)	2.0	20.0	2.0
Beam Size at Lens, b, (mm)	6.3	30.0	3.0
Lens Focal Length, $f_o$ , (mm)	25.4	200	200
MPE, 8 hr ( $\text{Wcm}^{-2}$ )	$5 \times 10^{-3}$	0.1	$1 \times 10^{-3}$
MPE, 10s ( $\text{Wcm}^{-2}$ )	$5 \times 10^{-3}$	0.1	_____
MPE, 0.25s ( $\text{Wcm}^{-2}$ )	_____	_____	$2.5 \times 10^{-3}$

Laser Safety © Laser Institute of America

39

## The Nominal Hazard Zone, NHZ: Nominal Hazard Zones (NHZ) for Various Lasers

### Nominal hazard distance (m)

Laser Type	Exposure Duration	Direct	Lens-on Laser	Diffuse
Nd:YAG	10 s	790	6.4	0.8
CO <sub>2</sub>	10 s	399	5.3	0.4
Argon	0.25 s	505	33.6	0.25

Laser Safety © Laser Institute of America

40

## Non-Beam Hazards & Z136.1

- “Non-beam Hazards” section provides guidance on:
  - Electrical hazards (Sec. 7.2.1)
  - Collateral and plasma radiation (Sec. 7.2.2)
  - Fire hazards (Sec. 7.2.3)
  - Explosion hazards (Sec. 7.2.4)
  - Mechanical hazards associated with robotics (Sec. 7.2.5)
  - Noise (Sec 7.2.6)
  - Laser generated airborne contaminants (Sec. 7.3.1)
  - Compressed gases (Sec. 7.3.2)
  - Laser dyes and solvents (Sec. 7.3.3)
  - Assist gases (Sec 7.3.4)
  - Biological agents (Sec. 7.4)
  - Human factors (Sec. 7.5)

## Non-Beam Hazards: Electrical

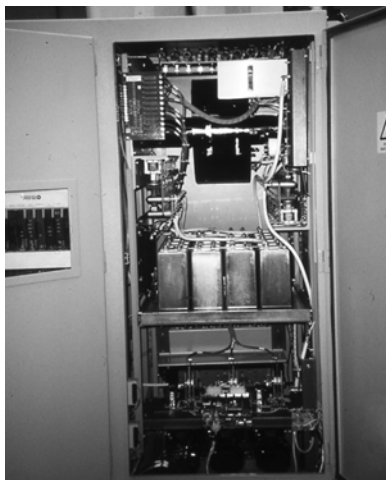

- Shock
- Electrocution
- Electrically generated fires
- **Not** unique to lasers
- Electrocution: 5th leading cause of work related injury/death in U.S.
- Electrocution: cause of at least 10 laser-related death
- 2nd most often reported cause of laser accidents

## Non-Beam Hazards

### Laser Generated Air Contaminants (LGAC)

- Generated when class 3b or 4 laser beams interact with matter
- LGAC depends upon target material, cover gas and beam irradiance
- Difficult to predict what LGAC is released into air

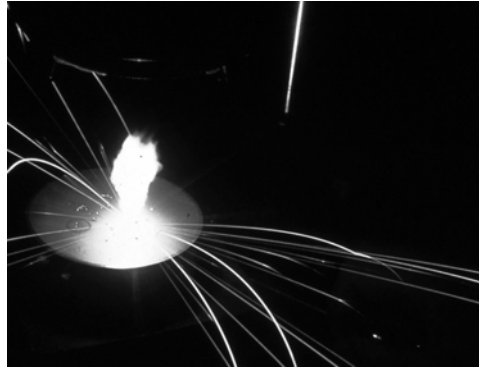

## Non-Beam Hazards

### Laser Generated Air Contaminants (LGAC)

- When target irradiance reaches  $10^7 \text{ W} \cdot \text{cm}^{-2}$ 
  - Target materials may liberate carcinogenic, toxic and noxious airborne contaminants
- LGAC released may be gaseous or particulate
- LSOs responsibility to ensure that any IH issue be addressed and he/she may consult with Industrial Hygienist

## Non-Beam Hazards: Compressed Gas

- Rapid release may propel tank
- “low” concentration in tank may produce high concentration in air
- Release of “non-toxic” gases may produce asphyxia due to oxygen displacement



## Control Measures: Enclosed Beam Path

- Tubular, anodized aluminum beam tubes provide rigid mounting
- Here, encloses beam from laser into beam bender then to regenerative amplifier.

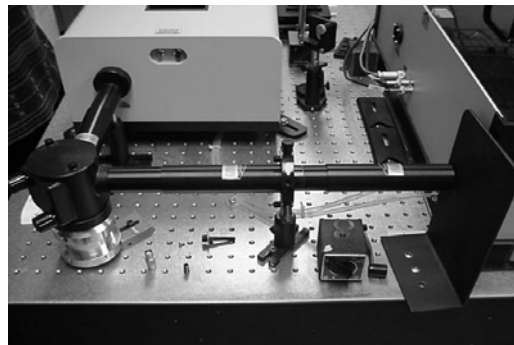

## Control Measures: Enclosed Beam Path

- Use of closed-circuit TV (CCTV) to view micro-material processing application
- Processing occurs in chamber beneath laser; access door is interlocked to laser



## Control Measures: Beam Block

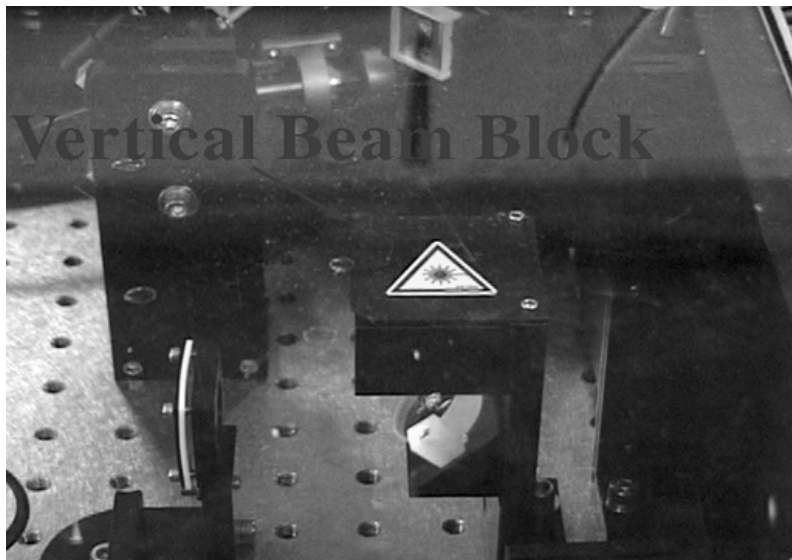

## Control Measures: Beam Stop

Confines the beam to the edge of the table using a metal barrier.



## Control Measures EYE PROTECTION

- Wavelength compatibility
- Attenuation at that Wavelength
- Visual Transmittance
- Comfort and Fit
- Training
- Inspection
- Storage



## Control Measures Wavelength Compatibility

- Visible beam was transmitted through lens and damaged carbon paper
- IR-C beam was absorbed by and damaged plastic lens, while carbon paper is intact

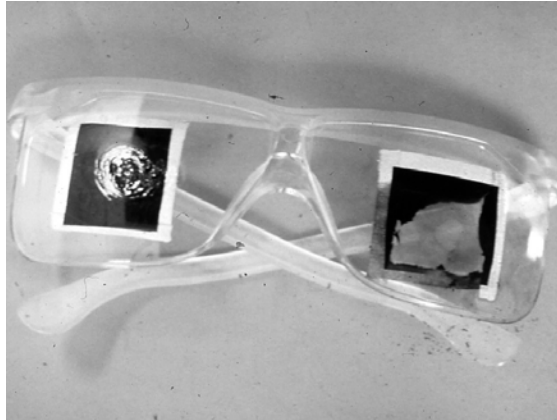

## Control Measures Optical Density



Eyewear must be marked with OD as a function of wavelength

## Control Measures

### Electrical Hazards Controls – Work Practices

- Work on deenergized parts of electrical systems
- Use insulated tools
- Use insulating blankets & covers as applicable
- Don't wear highly conductive items on hands or arms

## Control Measures

### Laser Generated Air Contaminants (LGAC)

- Control measures
  - Exhaust ventilation
    - Hoods, ducts, air cleaners, and fans
    - Comply with latest version of *Industrial Ventilation & Fundamentals Governing the Design & Operation of Local Exhaust Systems* (ANSI Z9.2)
  - Respiratory protection
    - Used to control brief exposure or as interim control until engineering control are put in place
    - Compliance with OSHA (29CFR 1910.134)

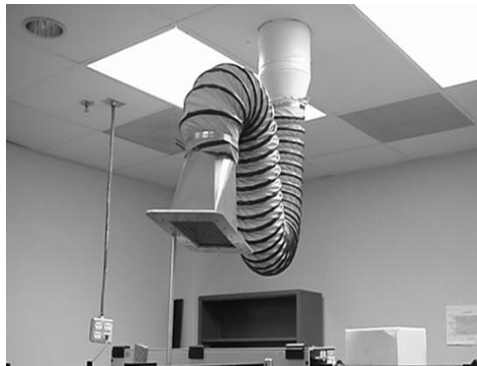

## Control Measures: Compressed Gas

- Hazardous gases shall be contained in an approved exhausted gas cabinet
- Shall have a sensor and alarm to detect leaks
- Shall be stored according to OSHA and Compressed Gas Association requirements



## Time to summarize and ask questions

- Do you now understand the potential hazards and risks?
- Is laser safety achievable, the answer is YES!
- If you understand the hazards, you will take appropriate hazard control measures.
- Your laser safety program can be
  - Maintenance mode
  - Pro-active mode
  - You need to decide what fits you best and your resources
  - Does your program take effort? Yes!

## Thank You!

- Gus Anibarro
  - LIA Education Manager
- 800-345-2737 or 407-380-1553
- [gus@laserinstitute.org](mailto:gus@laserinstitute.org)
- [www.laserinstitute.org](http://www.laserinstitute.org)