

Interior Sign Standards Manual

Signage Guidelines

UNIVERSITY OF MICHIGAN - DEARBORN

Dearborn, Michigan



Table of Contents

Interior Sign Standards Manual

Introduction to Signage	3
Overview of Interior Sign Standards Manual	4
Specification Guidelines	6
Materials	7
Colors	9
Artwork	
Typography & Alphabet	10
Arrows	11
Symbols	12
Specification Exceptions	13
Orientation Signage	14
E Directory	15
E.1 Small Directory	16
E.2 Large Directory	17
Identification Signage	18
A Room Identification	19
A-WB Room Identification - with Backer	20
A.1 Room Identification - Permanent	21
A.1.1 Room Identification - Insert	22
A.1.2 Room Identification - Minor	23
A.2 Restroom Identification	24
A.3 Classroom/Office Identification - Insert	25
Directional Signage	26
D Directional	27
D.S Directional - University Seal	28
D.1 Directional - Single Unit	29
D.1.1 Directional - Single Unit Large	30
Informational Signage	31
I Campus Phone	32
Life Safety Signage	33
F Stair Identification	34
H Occupancy	35
B Elevator Warning	36
C Exit Stair	37
Fabrication Drawings	38
Installation Standards	58

INTRODUCTION TO SIGNAGE

The following information serves as an overview of the Interior Sign Standards Manual.

Introduction to Signage

Overview of the Interior Sign Standards Manual

This manual includes the designs and guidelines to regulate the implementation of a standard sign system throughout University of Michigan - Dearborn. The Interior Sign Standards Manual has been developed in response to a need for a comprehensive master sign program. The sign system is directed toward establishing a distinct and professional graphic image throughout the facilities. The system provides consistent visual standards to assist operational functions and to establish a practical and economical method for implementation within all of the buildings. A standardized system is dependent upon a uniformity of typography, size, spacing, layout, nomenclature, simplicity of components, and color.

This sign system has been designed to accommodate simple and concise language for assisting the traveler to their destination. Each sign type has been developed to satisfy a specific communication requirement and has a special function as an integral part of the overall program. The system has also been designed to meet the requirement of uncomplicated in-house capabilities for sign maintenance and future sign fabrication.

The interior sign system at the University has been designed to comply with all applicable provisions of the 2010 Standards for Accessible Design (the updated ADA Accessibility Guidelines, ADAAG - <http://www.ada.gov/regs2010/2010ADAStandards/2010ADAstandards.htm>), effective in March 2011, which provides civil rights protection to disabled citizens. The Architectural and Transportation Barrier Compliance Board issued standards of design that would make all facilities accessible to disabled persons. The standards relating to signage would make all public facilities accessible to the visually impaired and blind. Wall mounted signs identifying permanent rooms and spaces are required to include, but are not limited to the following:

- A. Tactile copy must be all upper case and raised at least 1/32". Tactile characters must be sans serif, not italic, not oblique, script or highly decorative.
- B. The stroke width of the upper case "I" has to be 15% of the letter height or less. The character width of the uppercase "O" must be between 55% and 100% of the height of the corresponding uppercase "I".
- C. The copy height for tactile information must be between 5/8" and 2". If separate visual characters are provided, raised characters can be 1/2" and need not contrast with the background.
- D. The distance between characters on tactile copy must be a minimum of 1/8" and a maximum of 4 times the character stroke width. These distances are measured between the closest points of adjacent characters.
- E. Spacing between lines of tactile copy needs to be a minimum of 135% and a maximum of 170% of the corresponding upper case "I" height (measured from baseline to baseline).
- F. Braille must be Grade II and positioned directly below the corresponding raised characters. If text is multi-lined, Braille is placed below the entire body of text and separated 3/8" from any other tactile characters and 3/8" minimum from raised borders and decorative elements.
- G. Visual characters and symbols, and their background, are to have a non-glare finish. The color of raised characters must contrast as much as possible with their background to make sure signs are more legible for persons with low vision.
- H. Pictograms, selected from International Standards, are to be located within a 6" vertical void and accompanying text descriptions are to be located directly below the pictogram.

Introduction to Signage

Overview of the Interior Sign Standards Manual

In addition to permanent room signage identification, directional, informational and code required signage is to comply with ADA requirements as necessary.

Additional ADA requirements which have been addressed in this sign system include the following:

- Elements and spaces of accessible facilities have been identified by the international symbol of accessibility along with assembly areas.
- Mounting heights and locations for all signs are specific to meet the requirements.

The system proposed in this manual is a course of action to reinforce the University's efforts to establish a professional image through consistent visual graphics. Given the systems' correct implementation and with continued support and participation, it shall serve the University's needs for many years.

SPECIFICATION GUIDELINES

This section covers standard materials, colors, and artwork of typography, alphabet, arrows, and symbols.

Specification Guidelines

Materials

Photopolymer

Photopolymer is a light-sensitive, water-wash photopolymer face layer bonded to a phenolic base layer to produce raised numbers and text opened screen or subsurface, crisp Grade 2 Braille and tactile letters reproduced with precision and compliant with ADA guidelines. These are clear coated to resist cleaning agents and vandalism. Jet USA Corp., 800-528-1153, www.jetusa.com

Cast Acrylic Sheet

Clear, non-glare, matte finish as manufactured by Atohaas, Sheffield Plastics or GE Plastics.

Fasteners

Unless indicated otherwise, use the hardware as specified, or other devices required as noted on drawings, fabricated from metals that are noncorrosive to either the sign material or the mounting surface. Fasteners shall be adequate thickness, length and construction to properly secure sign elements. Any visible portion of any mounting device shall be finished to match the adjacent sign material color and texture, unless otherwise noted. Use stainless steel 300 series alloy where joining dissimilar materials.

Adhesives

- A. Clear Silicone Adhesive: as manufactured by General Electric, Dow Corning Manufacturing Co. or Pecora Corporation.
- B. Mounting Tape: very high bond (VHB), .045 inch thick acrylic foam closed cell adhesive tape; white approximate foam density of 50 lb/ft and 25 lb/in peel adhesion to stainless steel.
- C. Laminating Tape: .010 inch thick clear adhesive transfer tape with 9 lb/in peel adhesion to stainless steel.
- D. Metal Bonding / Acrylic Structural Adhesive.

Paint

Screening paint shall be manufactured by NAZ-DAR Company or an approved equal. Paint shall be mixed in sufficient quantities to assure consistent application of all surfaces in the specific color. Paints used for screening shall be specifically formulated for maximum durability and compatible in bonding with background coatings. Paints shall match building identification colors as noted.

Frames / Holders

- A. SLATZ extruded aluminum frame system components by Clarke Systems, 800-331-1891, www.clarkesystems.com
- B. SLATZ Capture photopolymer inserts and paper inserts with non-glare clear plastic lens by Clarke Systems, 800-331-1891, www.clarkesystems.com
- C. IM System with square edge components by APCO Signs, 877-988-APCO (2726), www.apcosigns.com

Paperstock / Inserts

Signage inserts are to be printed on standard white laser printer paper.

Specification Guidelines

Materials

Sign Backer

Sign backer for window application: 1/8” rigid acrylic backer to match sign base color, blue to match PMS 282. Backer to be rectilinear in shape, omitting the circular disc protrusion.

Process Types

Painting

A process conducted in a spray booth using architectural paints.

Screening

A process involving a stencil (negative) and applying a layer of ink to the surface using the stencil. Maybe be used on primary or raised surfaces.

Laser Printing

A process used on paper inserts.

Specification Guidelines

Colors

The use of strong visual graphics is vital for maintaining a consistent, high-quality, professional image and identity. In an effort to implement a standard system, an official color palette has been developed to complement interior spaces. These colors are comprised from the University color palette. Each color will be utilized in a consistent way on all interior signs throughout the campus.

*Note: the color samples shown in this manual are approximate representations only and should not be used to match finished colors. PMS color numbers refer to the Pantone Matching System used by printers worldwide to ensure accurate, consistent color and color match formulations. For further information, call Pantone, Inc., 800-222-1149.

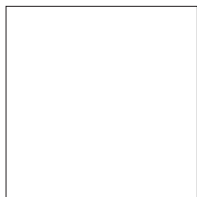

Color 1
White



Color 4
Black



Color 2
Blue

To match:
PMS 282C

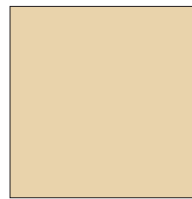

Color 5
Beige

To match:
PMS 7534C

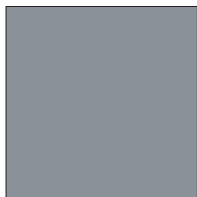

Color 3
Gray

To match:
PMS 423C

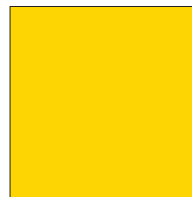

Color 6
Maize

To match:
PMS 7406C

Specification Guidelines

Artwork: Typography & Alphabet

Gills Sans

Alphabet and numerical example:

ABCDEFGHIJKLMNOPQRSTUVWXYZ
abcdefghijklmnopqrstuvwxyz 1234567890

Gills Sans is to be used for :

- Tactile characters
- Room numbers
- Floor numbers
- Directory headings
- Office name inserts
- Directory heading inserts
- Directional strips
- Informational text

Gills Sans Bold

Alphabet and numerical example:

ABCDEFGHIJKLMNOPQRSTUVWXYZ
abcdefghijklmnopqrstuvwxyz 1234567890

Gills Sans Bold is to be used for :

- Directory numbers
- Directory headings
- Accented information text (used selectively)

Specification Guidelines

Artwork: Arrows

Arrows

Arrows are to be used for :

- Wall directional strips
- Overhead directionals
- Informational text

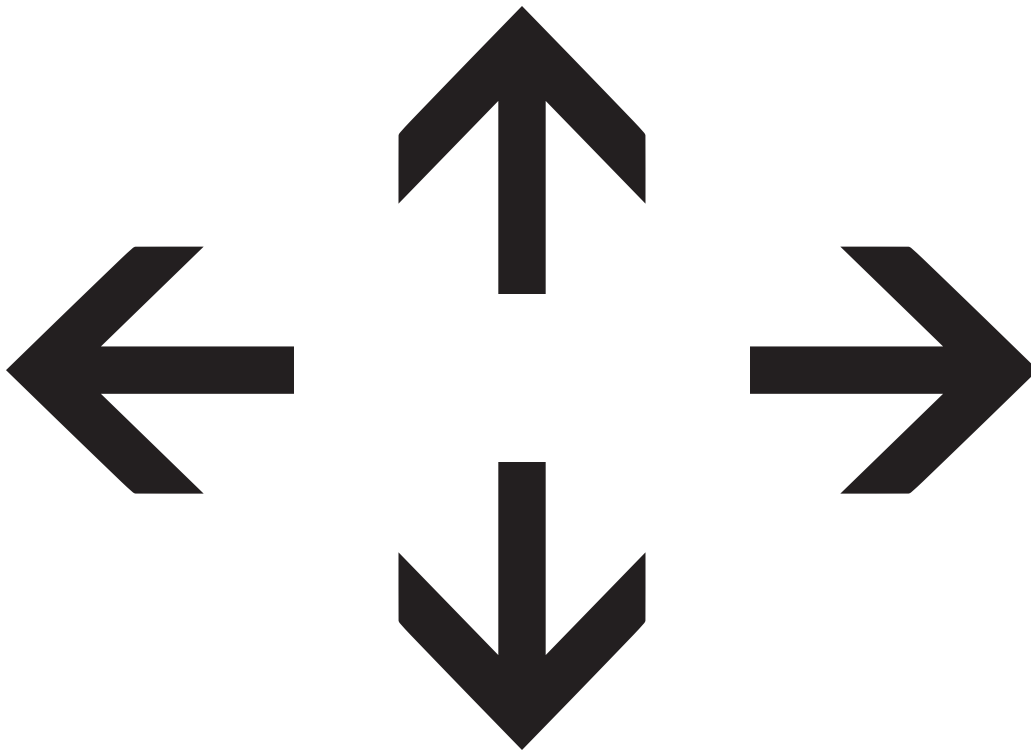

Specification Guidelines

Artwork: Symbols

Restroom - Men | Women



Other-abled



Restroom - Single / Unisex / Gender Inclusive

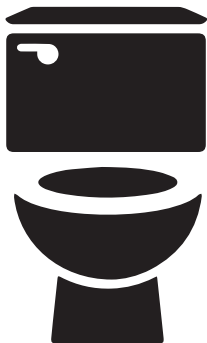

Changing Station



Stairs

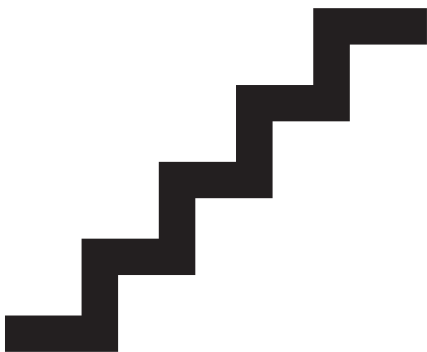

Fire Emergency



Specification Guidelines

Specification Exceptions

There are some buildings on campus that have pre-existing signage standards that differ from those established in this manual. The following are exceptions that need to be followed.

University Center Building:

- A. Sign Type E - Slat width of 21.5". Refer to Sign Type E Fabrication Drawings for more information.
- B. All Directory Board frame edges are Color-4 (black).

Natural Sciences Building:

- A. All Directory Boards - The original, printed white directory board slats are "Stratojet White". When ordering new slats, use paint "MP 93240 N Satin VI.0 DMP White", which was found to be the closest matching white.

ORIENTATION SIGNAGE

Orientation signs serve as introductory signs to a building or space. Orientation maps and directory listings orient visitors to where they are located within the facility and provide key information to help them find their destination. Orientation signs should be displayed at building entrance, elevator lobbies, and corridor junctions.

Orientation Signage

Sign Type E: Large Directory

Function and Use

Large directories are to be used in facilities where a maximum number of directory listings and destination information is required. This type of directory may have changeable paper insert slats. Recommended total number of listings: 22.

Sign Face

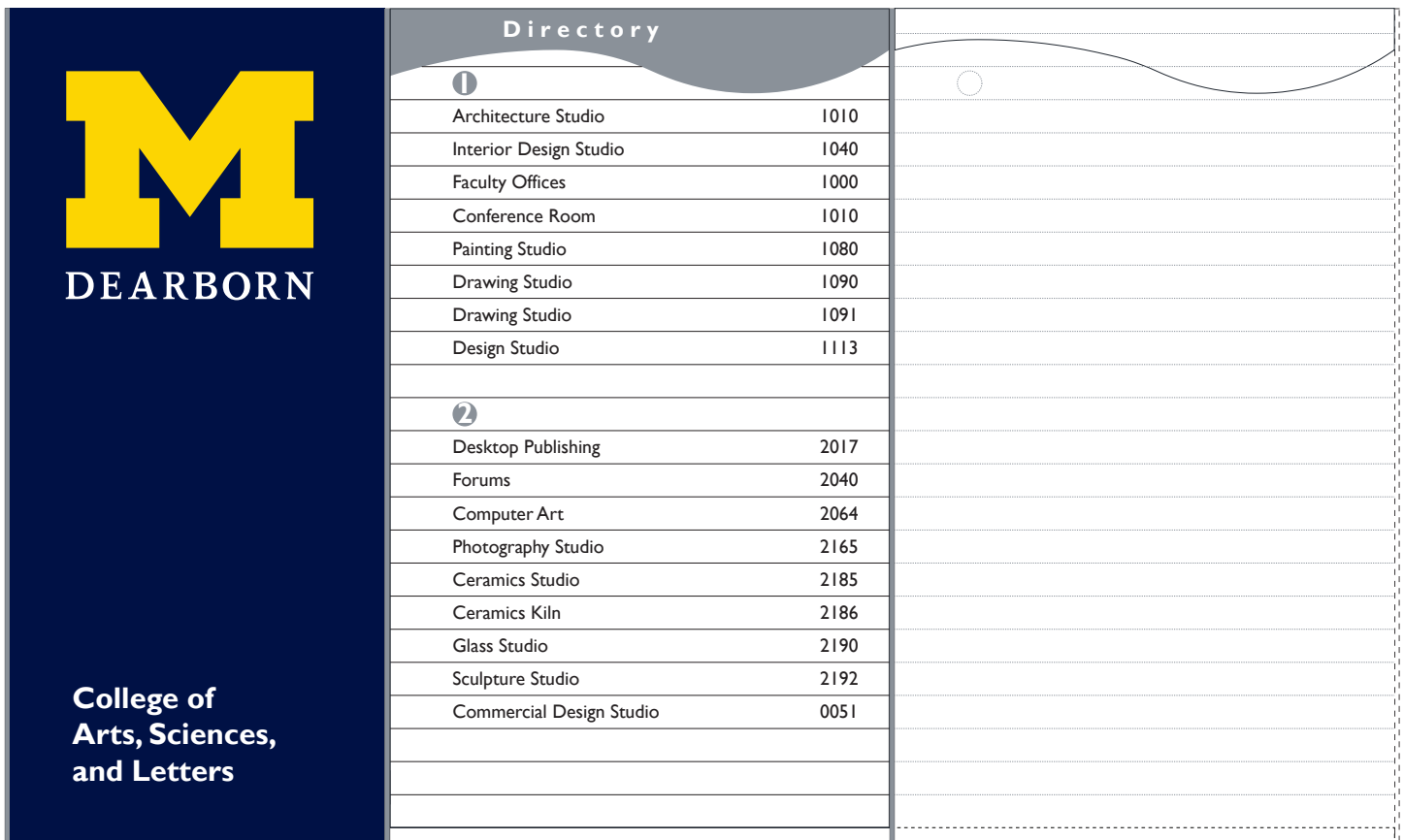

References

Fabrication Drawings: sign construction details and message layout
Installation Standards: typical mounting location

Orientation Signage

Sign Type E.1: Small Directory

Function and Use

Small directories are to be used in facilities where a small number of directory listings and destination information is required. This type of directory may have changeable paper insert slats.

Sign Face

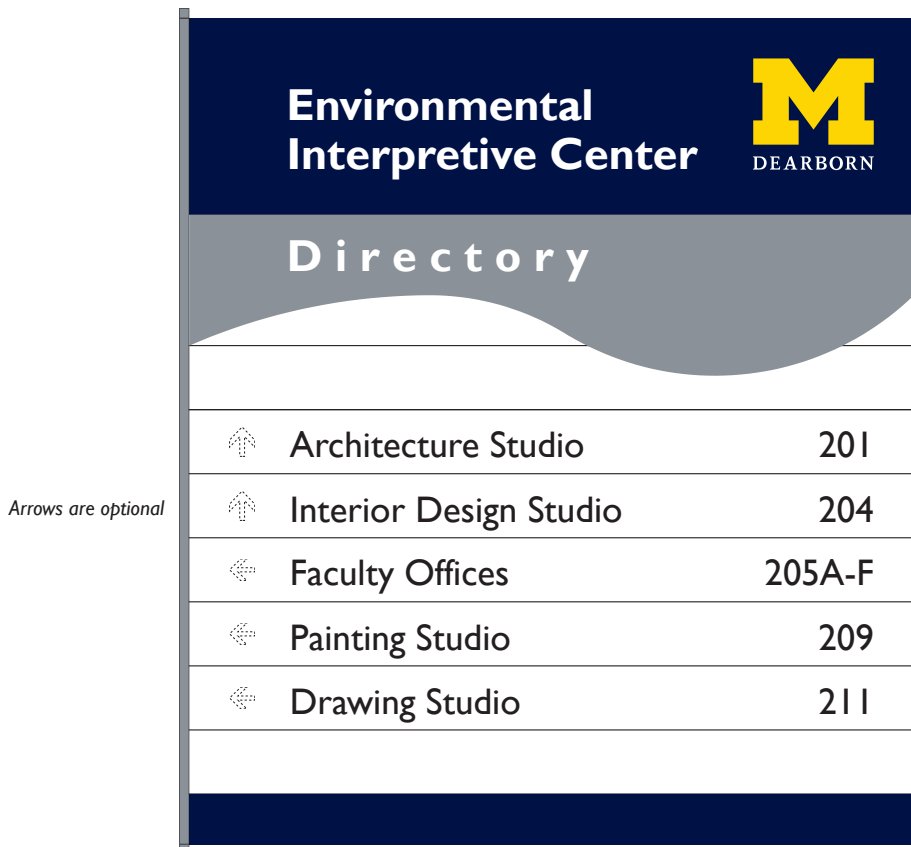

References

Fabrication Drawings: sign construction details and message layout
Installation Standards: typical mounting location

Orientation Signage

Sign Type E.2: Large Directory

Function and Use

When dimensional constraints exist this E.2 large directory is used in facilities where a maximum number of directory listings and destination information is required. This type of directory may have changeable paper insert slats. Recommended total number of listings: 22.

Sign Face

Environmental Interpretive Center			
Directory			
①		③	
Architecture Studio	1010	Architecture Studio	1010
Interior Design Studio	1040	Interior Design Studio	1040
Faculty Offices	1000	Faculty Offices	1000
Conference Room	1010	Conference Room	1010
Painting Studio	1080	Painting Studio	1080
Drawing Studio	1090	Drawing Studio	1090
Drawing Studio	1091	Drawing Studio	1091
Design Studio	1113	Design Studio	1113
②			
Desktop Publishing	2017		
Forums	2040		
Computer Art	2064		
Photography Studio	2165		
Ceramics Studio	2185		
Ceramics Kiln	2186		
Glass Studio	2190		
Sculpture Studio	2192		
Commercial Design Studio	0051		

References

Fabrication Drawings: sign construction details and message layout
 Installation Standards: typical mounting location

IDENTIFICATION SIGNAGE

Identification signs are vital for communicating the use and purpose of rooms and areas of importance within the facility to visitors, students, and staff. Typical uses include signs for class rooms, mechanical rooms, restrooms, offices, and conference rooms. Identification signs must comply with the Americans with Disabilities Act (ADA) when they identify permanent rooms or spaces. This means that they require a tactile room number and corresponding Braille message.

Identification Signage

Sign Type A: Room Identification

Function and Use

Used to identify permanent rooms within the building.

Sign Face



References

Fabrication Drawings: sign construction details and message layout
Installation Standards: typical mounting location

Identification Signage

Sign Type A-WB: Room Identification - with Backer

Function and Use

Used to identify permanent rooms within the building with a thicker backer. For use above APCO framing system.

Sign Face



References

Fabrication Drawings: sign construction details and message layout
Installation Standards: typical mounting location

Identification Signage

Sign Type A. I: Room Identification - Permanent

Function and Use

Used to identify the names of permanent rooms that require clear identification. This identification is to be utilized when room name and function will not be altered (e.g., copy room).

Sign Face



References

Fabrication Drawings: sign construction details and message layout
Installation Standards: typical mounting location

Identification Signage

Sign Type A.I.I: Room Identification - Insert

Function and Use

Used to identify the names of classrooms and offices that require flexible identification of room name and/or function.

Sign Face



References

Fabrication Drawings: sign construction details and message layout
Installation Standards: typical mounting location

Identification Signage

Sign Type A.1.2: Room Identification - Minor

Function and Use

Used to identify minor rooms that require a number only. This identification is to be utilized when room name and/or function are of no importance to the public (e.g., mechanical rooms, janitor's closets).

Sign Face



References

Fabrication Drawings: sign construction details and message layout
Installation Standards: typical mounting location

Identification Signage

Sign Type A.2: Restroom Identification

Function and Use

Used to identify restroom location.

Sign Face



References

Fabrication Drawings: sign construction details and message layout
Installation Standards: typical mounting location

Identification Signage

Sign Type A.3: Classroom / Office Identification - Insert

Function and Use

Used to identify the names of classrooms and offices that require flexible identification of room name, function, hours available, occupants name, and/or title.

Sign Face



References

Fabrication Drawings: sign construction details and message layout
Installation Standards: typical mounting location

DIRECTIONAL SIGNAGE

Directional signs provide directional information to the visitor along primary corridors, elevator lobbies, and at pedestrian junctions.

Directional Signage

Sign Type D: Directional

Function and Use

Used to provide directional information to the visitor along main corridors, at elevator lobbies, and at pedestrian junctions. This type of directory may have changeable paper insert slats. Recommended total number of listings (but not limited to): 5.

Sign Face

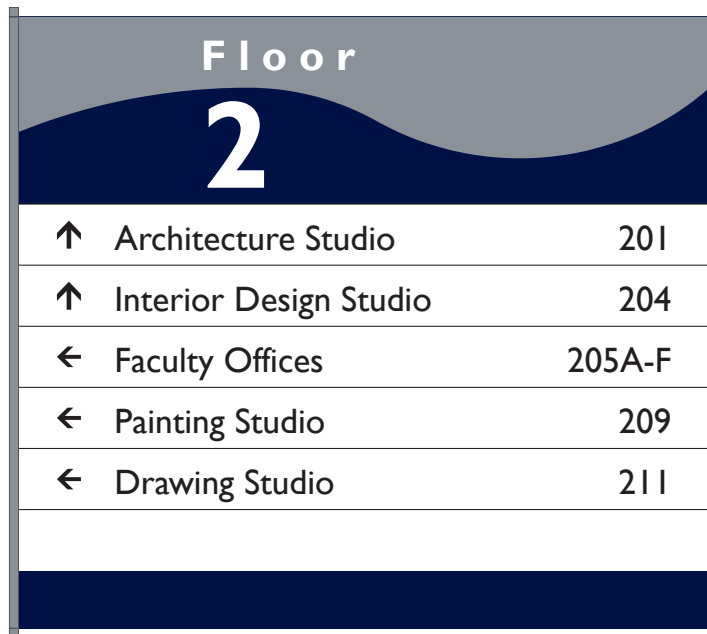

References

Fabrication Drawings: sign construction details and message layout
Installation Standards: typical mounting location

Directional Signage

Sign Type D.S: Directional - Block M

Function and Use

Used to provide directional information only for the Environmental Interpretive Center or when the display of the University seal is deemed necessary. This type of directory may have changeable paper insert slats. Recommended total number of listings (but not limited to): 5.

Sign Face

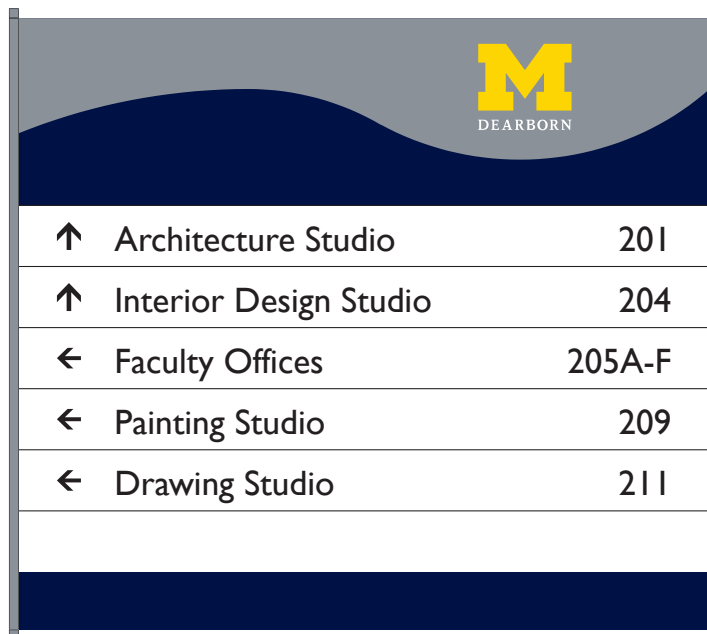

References

Fabrication Drawings: sign construction details and message layout
Installation Standards: typical mounting location

Directional Signage

Sign Type D.1: Directional - Single Unit

Function and Use

Used to provide minimal directional information to the visitor along secondary corridors and pedestrian junctions. Cap ends are required if more than one insert is used. This type of directory may have changeable paper insert slats. Recommended total number of listings: 10.

Sign Face

↑	Architecture Studio	201
---	---------------------	-----

↑ Architecture Studio 201		
↑ Interior Design Studio 204		
←	Faculty Offices	205A-F
←	Painting Studio	209
←	Drawing Studio	211

References

Fabrication Drawings: sign construction details and message layout
Installation Standards: typical mounting location

Directional Signage

Sign Type D.I.I: Directional - Single Unit Large

Function and Use

Used to provide minimal directional information to the visitor along secondary corridors and pedestrian junctions. Cap ends are required if more than one insert is used. This type of directory may have changeable paper insert slats. Recommended total number of listings: 20.

Sign Face

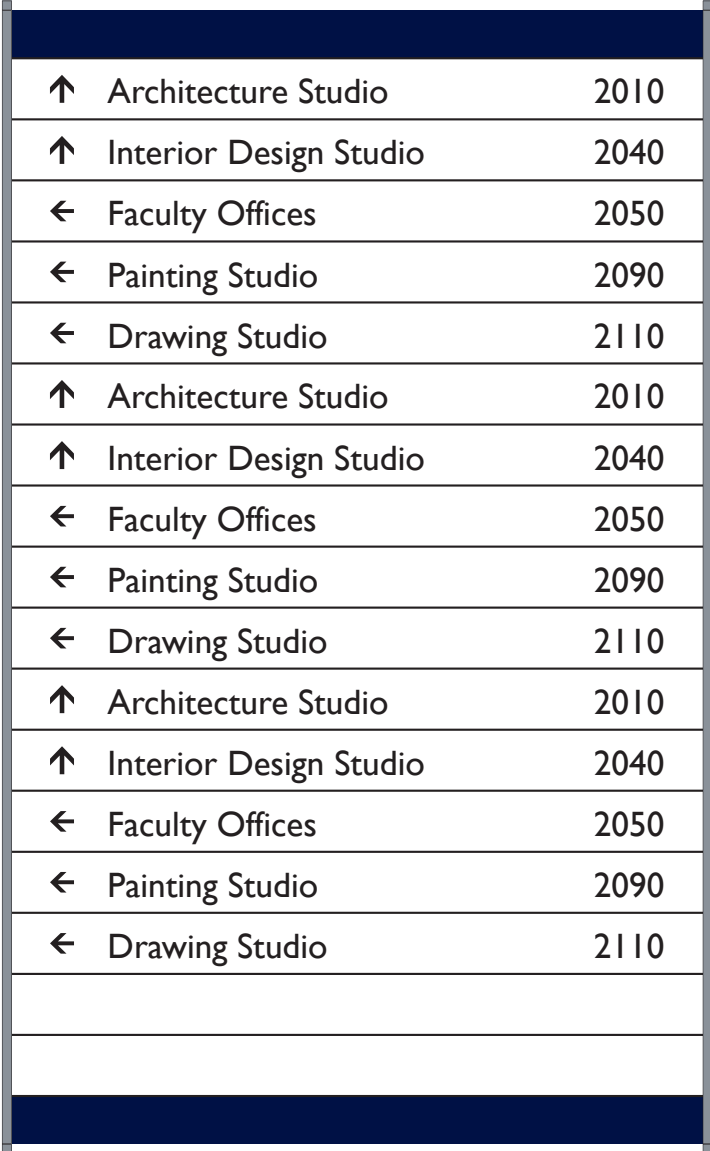

↑	Architecture Studio	2010
↑	Interior Design Studio	2040
←	Faculty Offices	2050
←	Painting Studio	2090
←	Drawing Studio	2110
↑	Architecture Studio	2010
↑	Interior Design Studio	2040
←	Faculty Offices	2050
←	Painting Studio	2090
←	Drawing Studio	2110
↑	Architecture Studio	2010
↑	Interior Design Studio	2040
←	Faculty Offices	2050
←	Painting Studio	2090
←	Drawing Studio	2110

References

Fabrication Drawings: sign construction details and message layout
Installation Standards: typical mounting location

INFORMATIONAL SIGNAGE

Informational signs provide special information to the visitor that is not common to many areas of the university. Typical locations for these signs can vary.

Informational Signage

Sign Type I: Campus Phone

Function and Use

Used to display small amounts of regulatory and special information to the student or visitor that is not common to many areas of the facility.

Sign Face



References

Fabrication Drawings: sign construction details and message layout
Installation Standards: typical mounting location

LIFE SAFETY SIGNAGE

Life safety signs display special regulatory information and symbols. Specific requirements within a facility are outlined in the Local, State, and Federal Building Codes. Review the codes that have jurisdiction within the respective facility to ensure compliance.

Life Safety Signage

Sign Type F: Stair Identification

Function and Use

Used to inform visitors and emergency services of the stair level and number, access levels, and how many levels up or down to exit the stairway. These signs appear at each landing in exit enclosures and must comply with local building codes.

Sign Face



References

Fabrication Drawings: sign construction details and message layout
Installation Standards: typical mounting location

Life Safety Signage

Sign Type H: Occupancy

Function and Use

Used to display specific regulatory information and to enforce the rules of the facility.

Sign Face

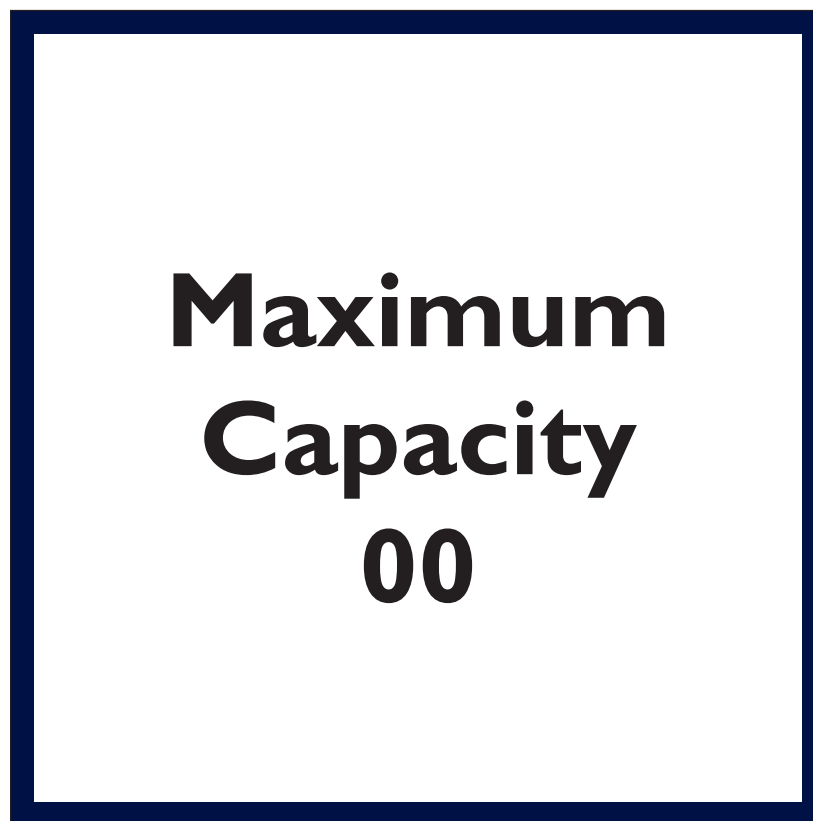

References

Fabrication Drawings: sign construction details and message layout
Installation Standards: typical mounting location

Life Safety Signage

Sign Type B: Elevator Warning

Function and Use

Used to provide code compliance signage at elevator landings.

Sign Face



References

Fabrication Drawings: sign construction details and message layout
Installation Standards: typical mounting location

Life Safety Signage

Sign Type C: Exit Stair

Function and Use

Used to provide code compliance signage at stair egress doors. These signs appear on the occupied side of the corridor on the door latch side.

Sign Face



References

Fabrication Drawings: sign construction details and message layout
Installation Standards: typical mounting location

FABRICATION DRAWINGS

Fabrication drawings contain detailed information required to manufacture individual sign type contained in the Standards Manual. The drawings may be used to fabricate signs at the University of Michigan - Dearborn or with an approved outside Sign Contractor. These drawings must be accompanied by a detailed Message Listing indicating the exact message content of each sign as needed for fabrication.

Identification Signage

Sign Type A: Room Identification

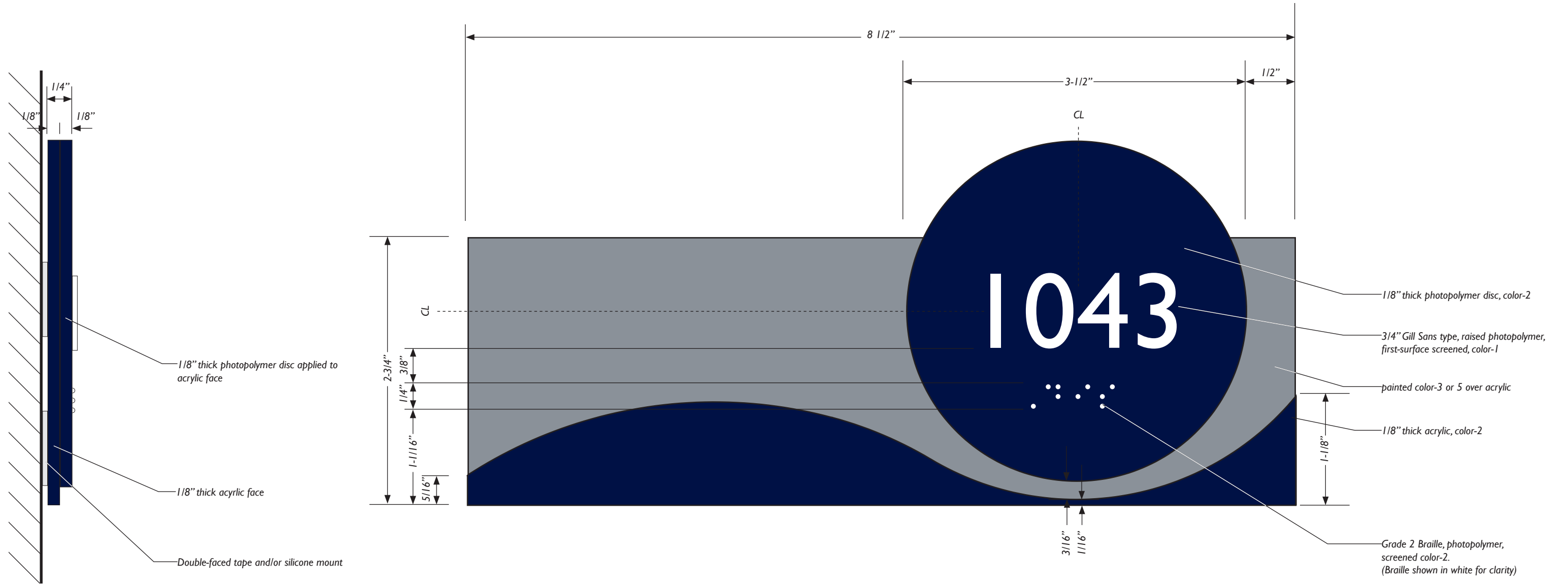

Side Elevation

Full Scale

Updated December 2020
Interior Sign Standards
Manual Signage Guidelines

Front

Elevation Full

Scale

Identification Signage

Sign Type A-WB: Room Identification - with Backer

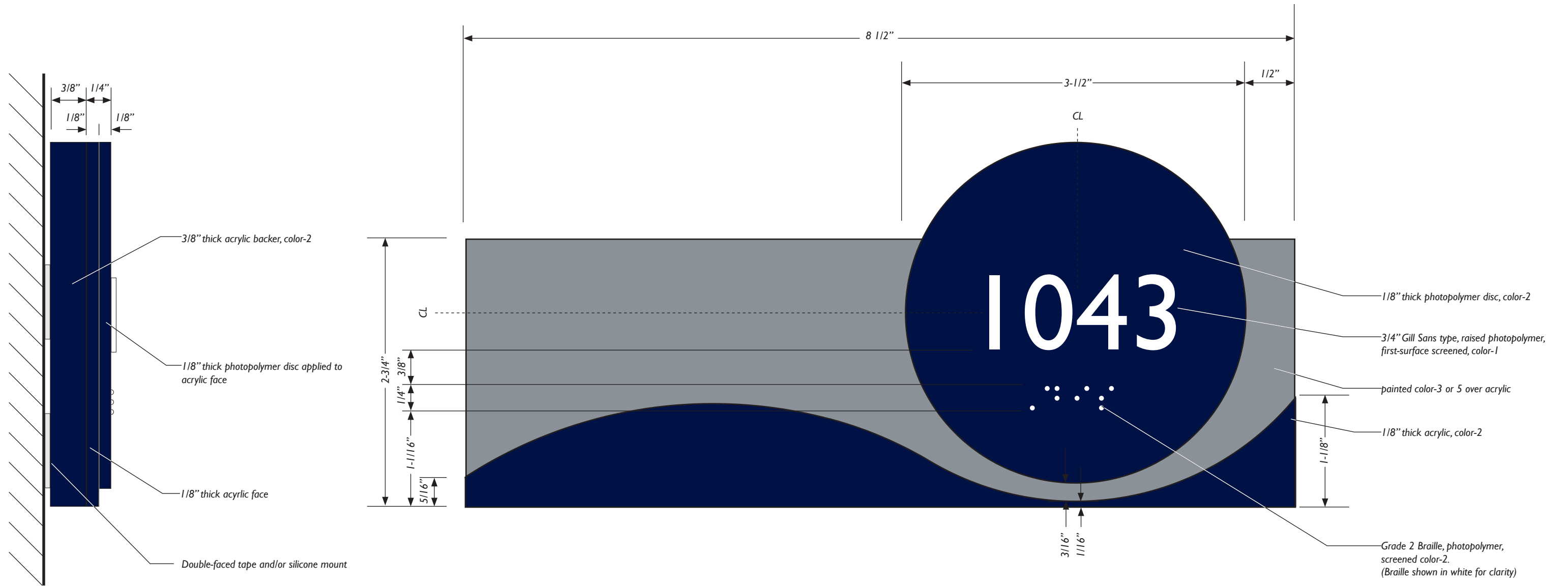

Side Elevation

Full Scale

Updated December 2020
Interior Sign Standards
Manual Signage Guidelines

Front

Elevation Full

Scale

Identification Signage

Sign Type A1: Room Identification - Permanent

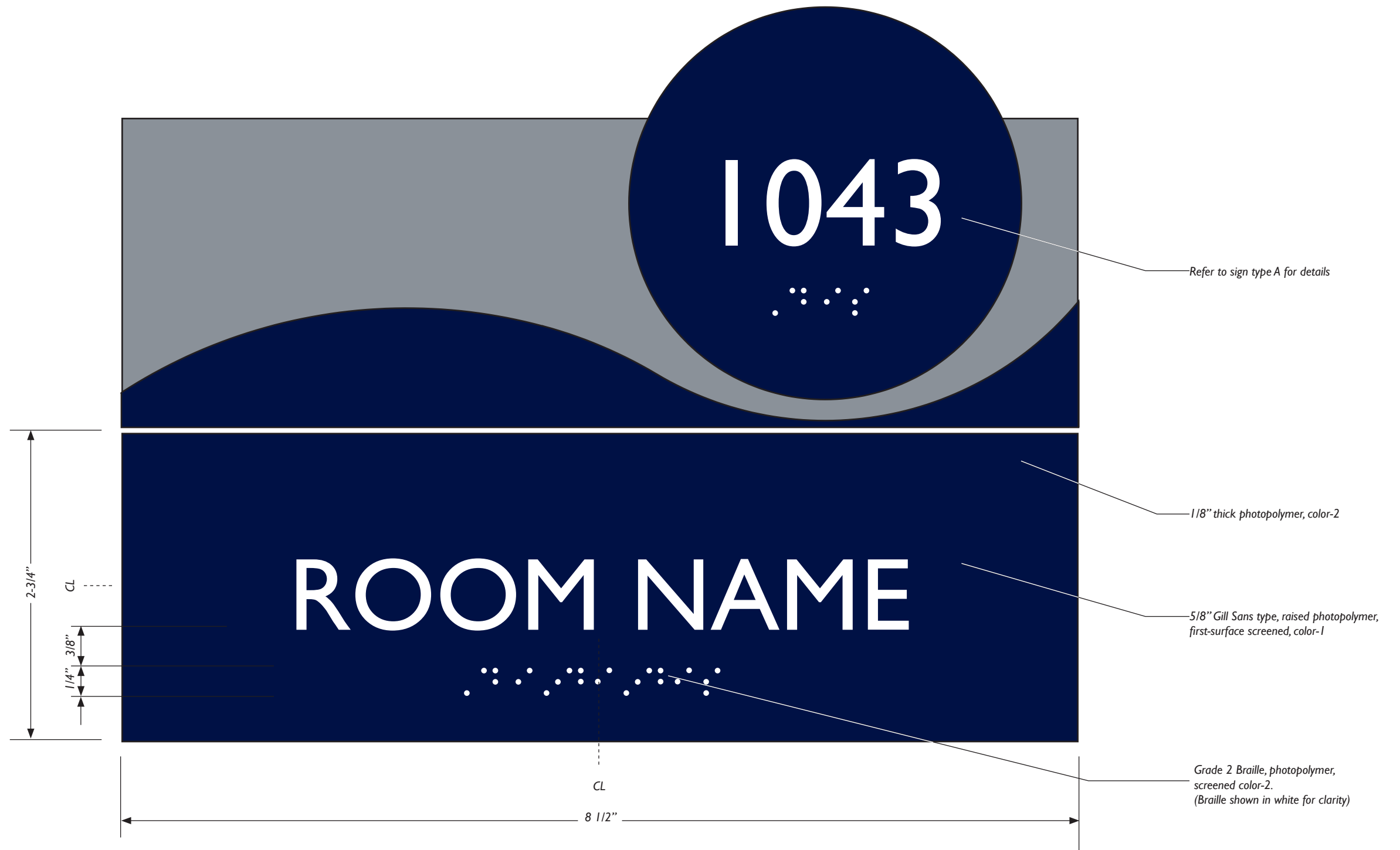
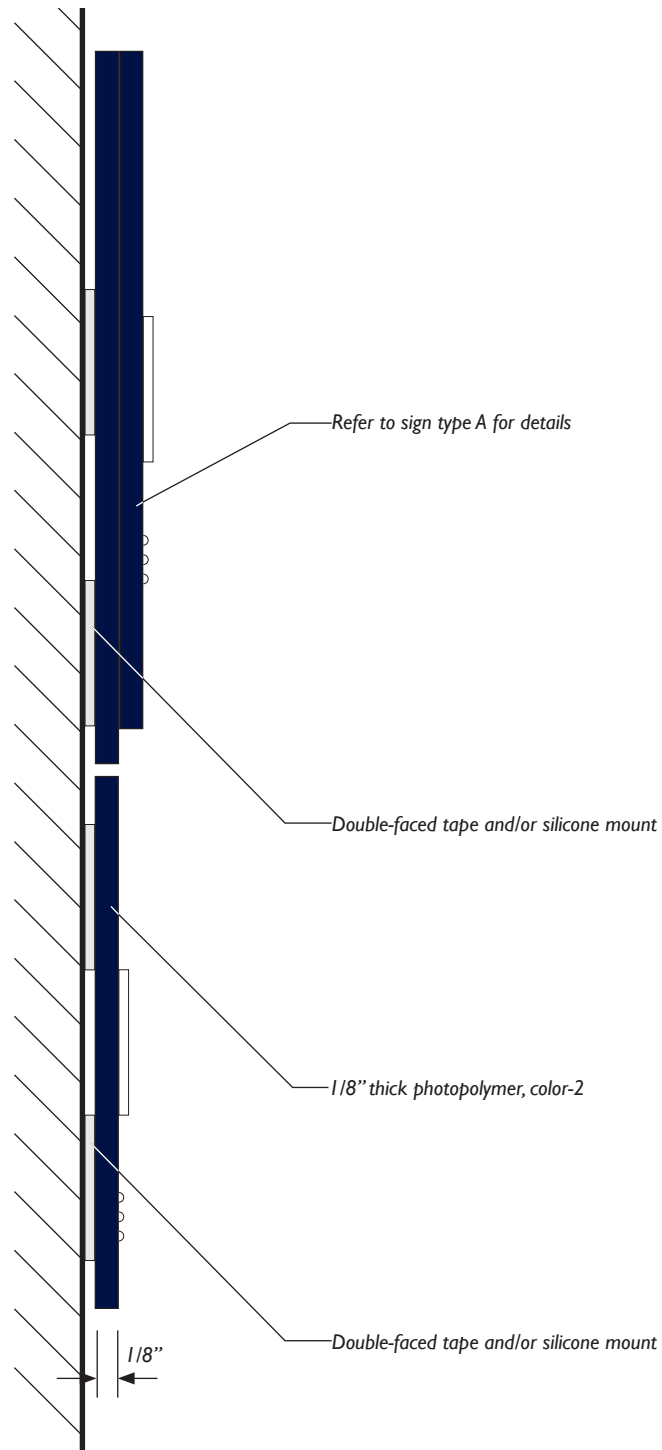

Side Elevation

Full Scale

Updated December 2020
Interior Sign Standards
Manual Signage Guidelines

Front Elevation Full Scale

Full Scale

Identification Signage

Sign Type A1.1: Room Identification - Insert



Side Elevation
Full Scale

Front Elevation Full Scale

Identification Signage

Sign Type A1.2: Room Identification - Minor

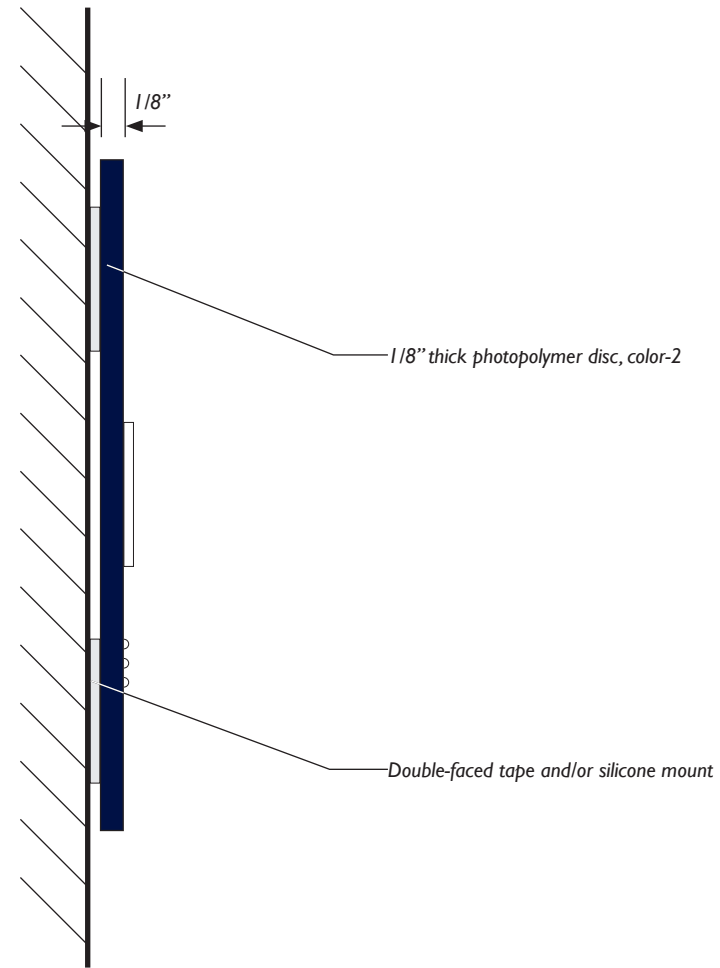

Side Elevation

Full Scale

Updated December 2020
Interior Sign Standards
Manual Signage Guidelines

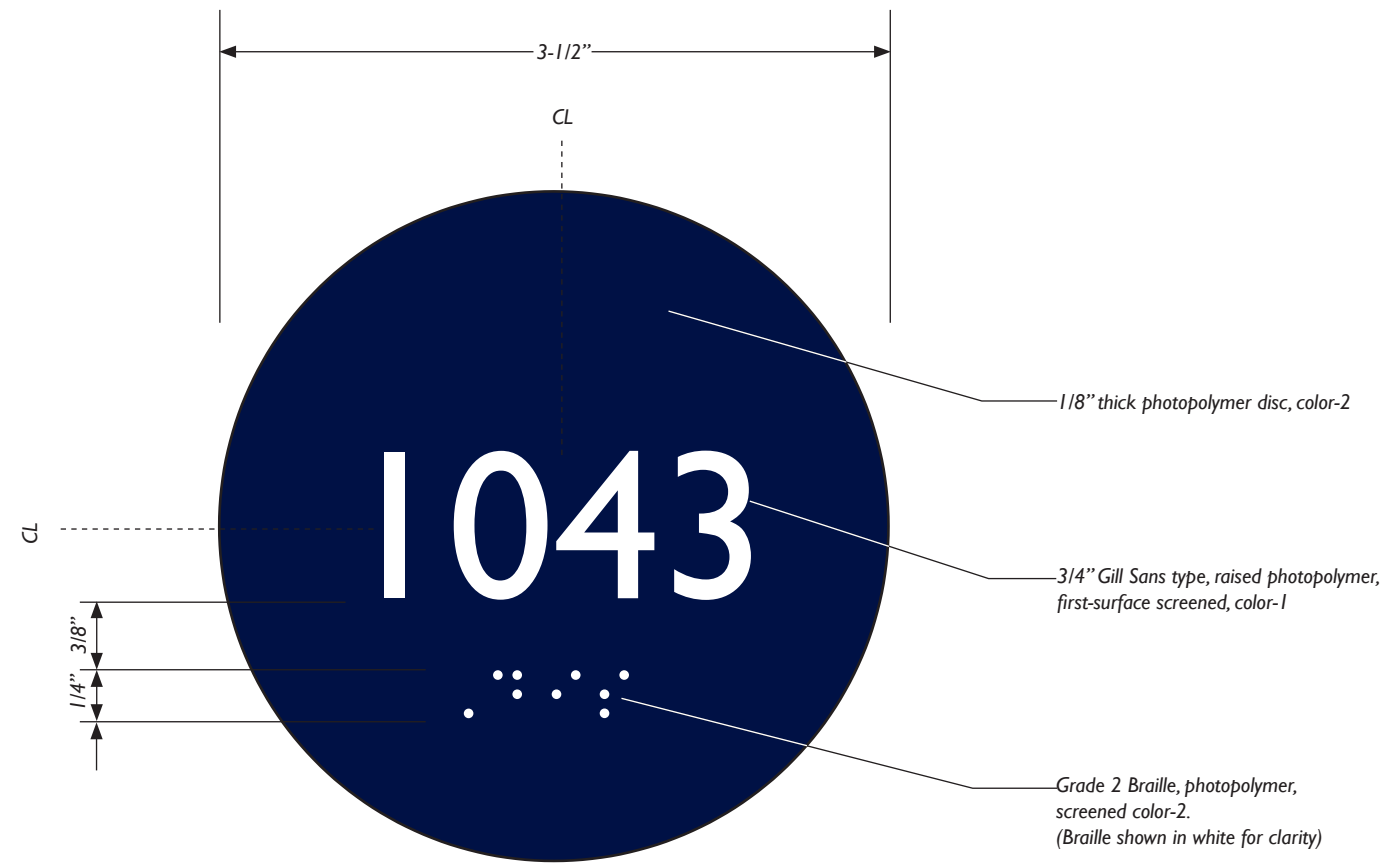

Front

Elevation Full

Scale

Identification Signage

Sign Type A2: Restroom Identification

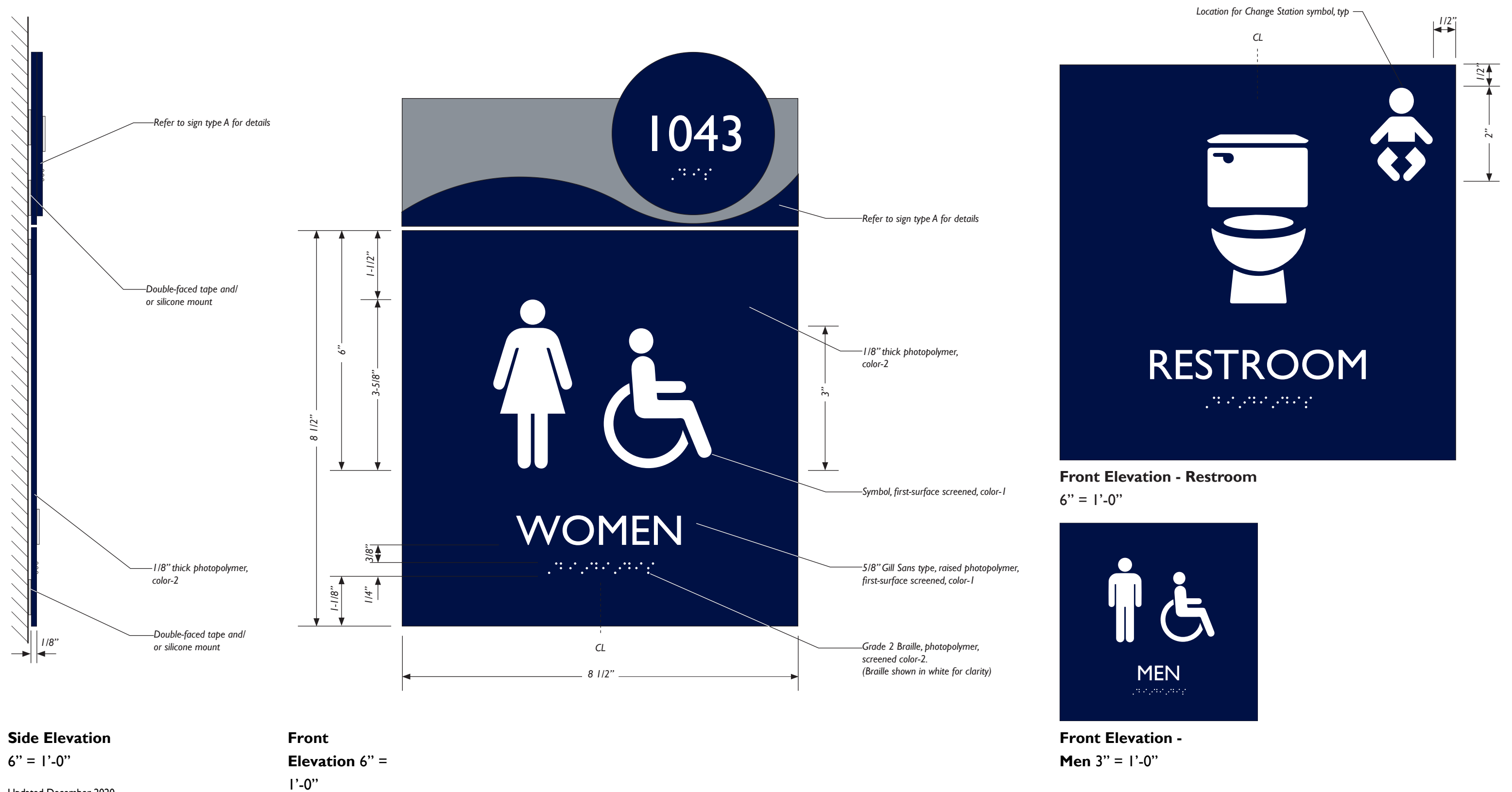

Identification Signage

Sign Type A3: Classroom / Office Identification - Insert

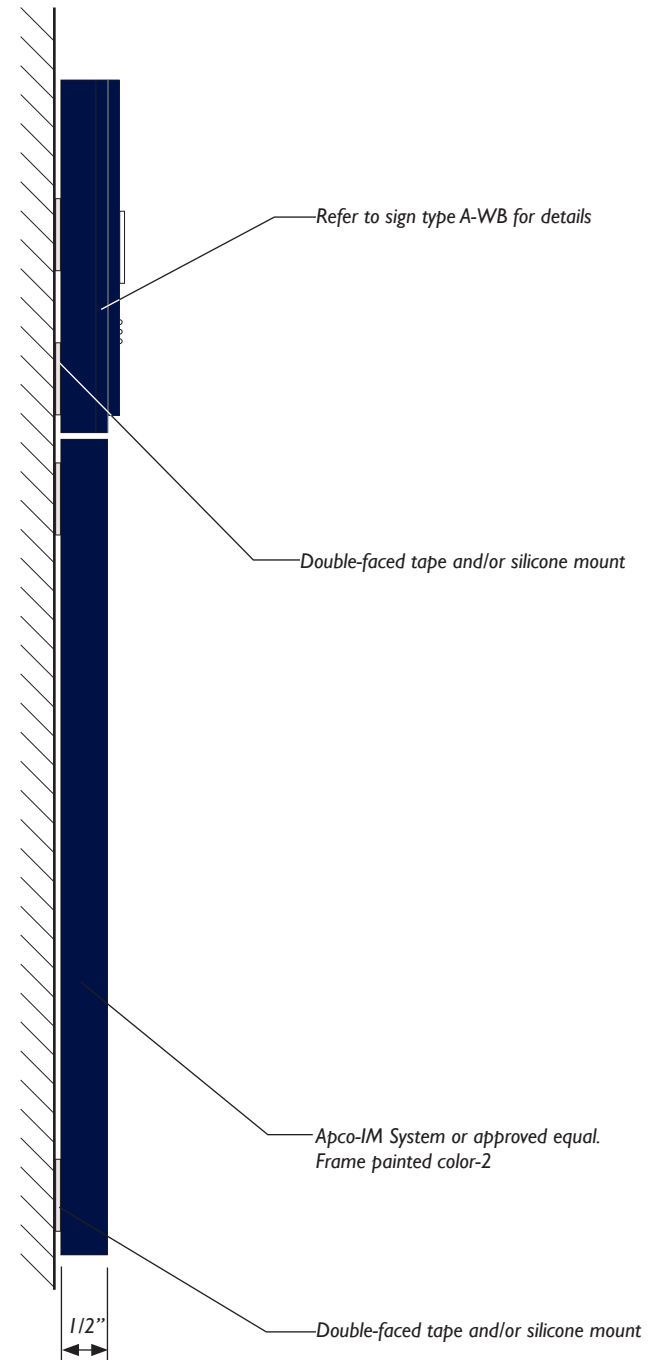

Side Elevation

6" = 1'-0"

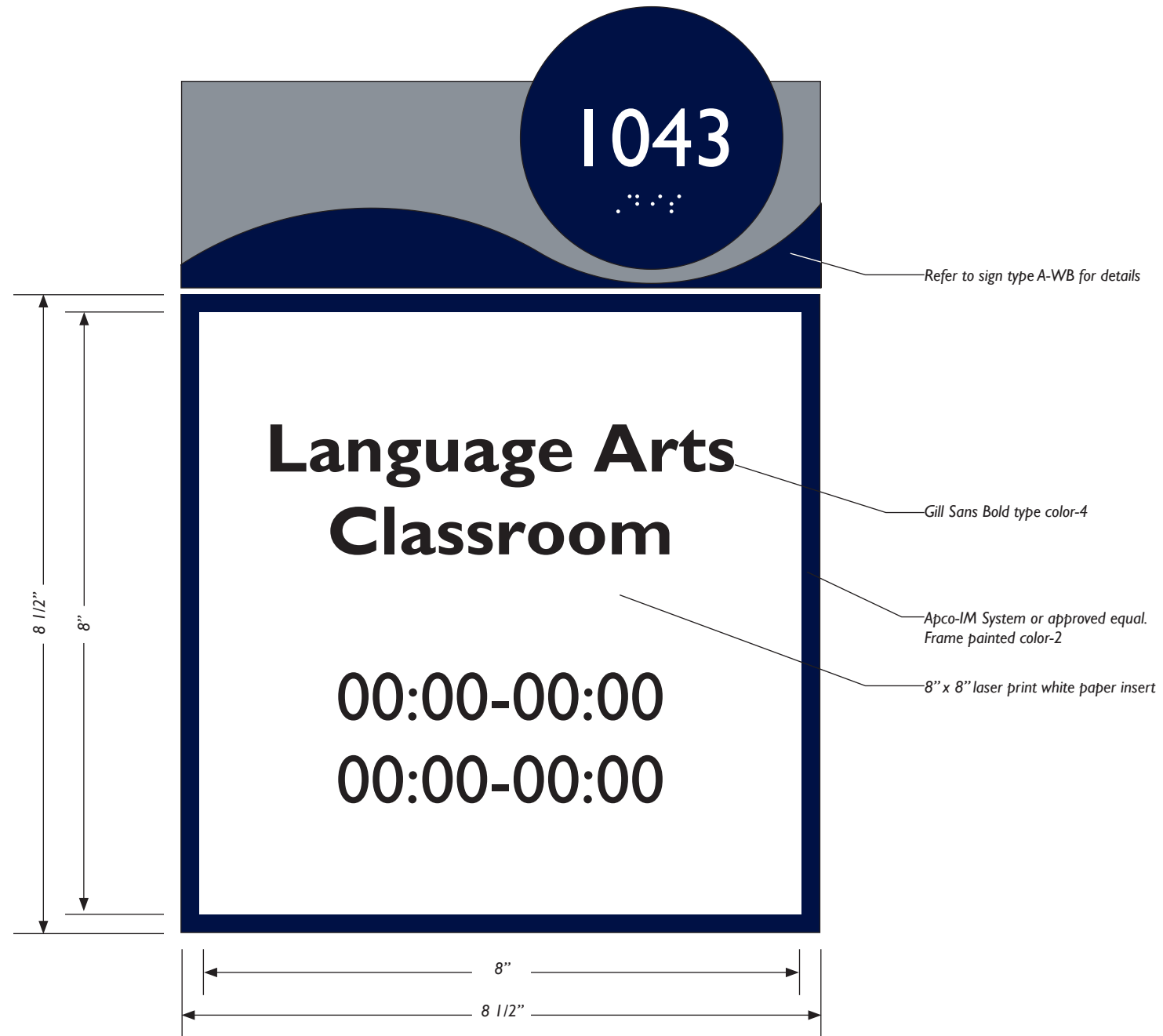

Front

Elevation 6" =

1'-0"

Life Safety Signage

Sign Type C: Exit Stair

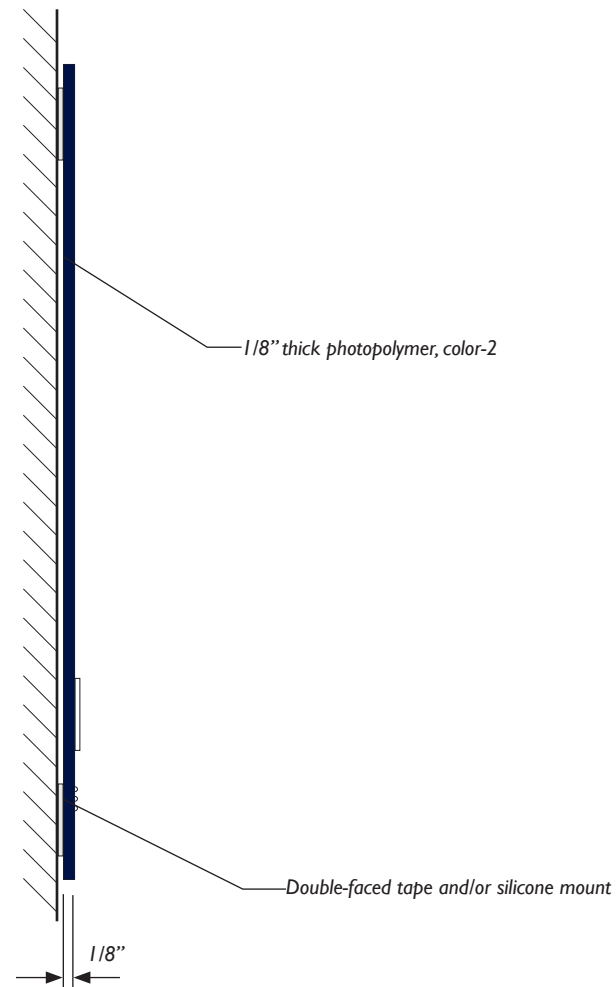

Side Elevation

6" = 1'-0"

Updated December 2020
Interior Sign Standards
Manual Signage Guidelines

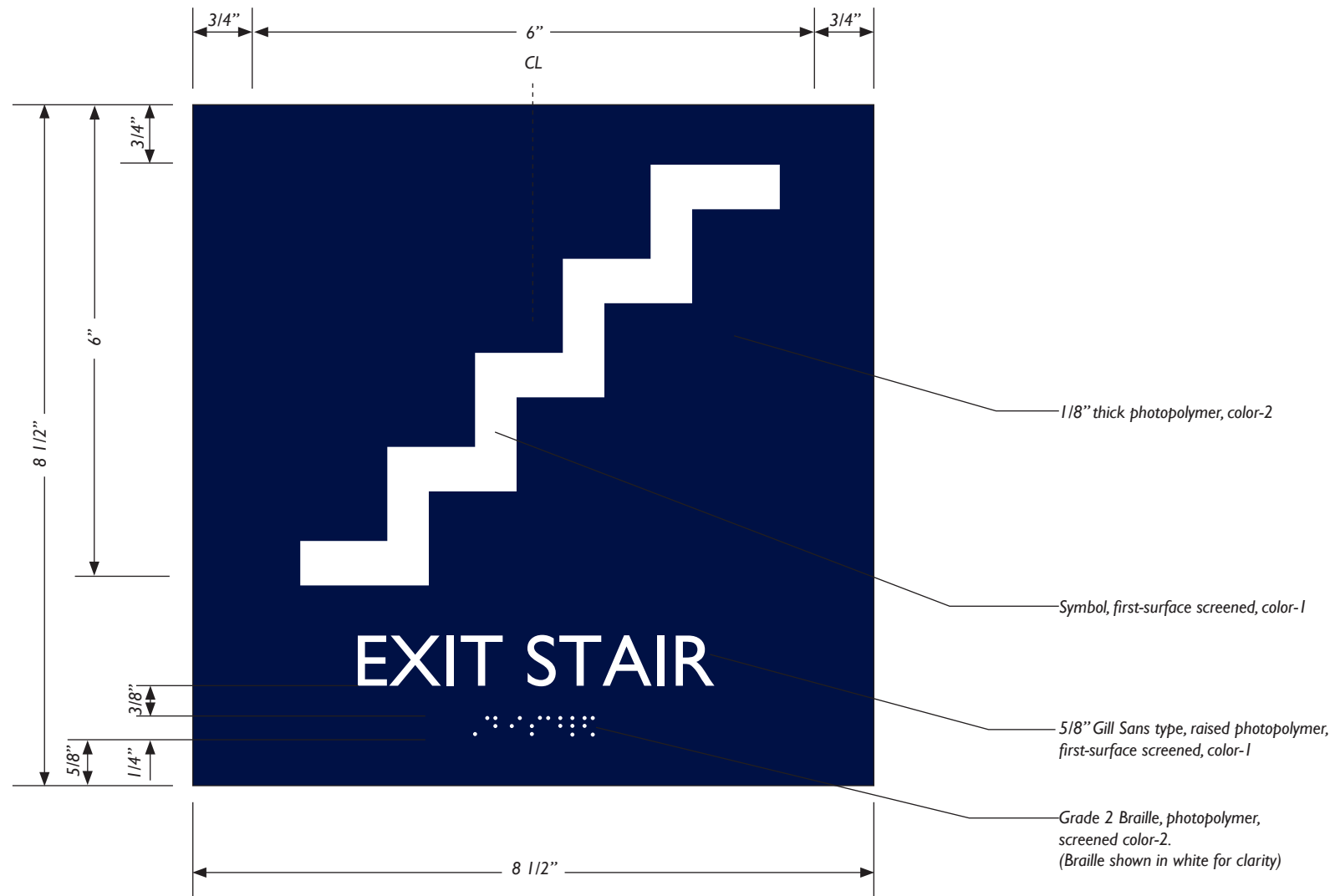

Front

Elevation 6" =

1'-0"

Directional Signage

Sign Type D: Directional

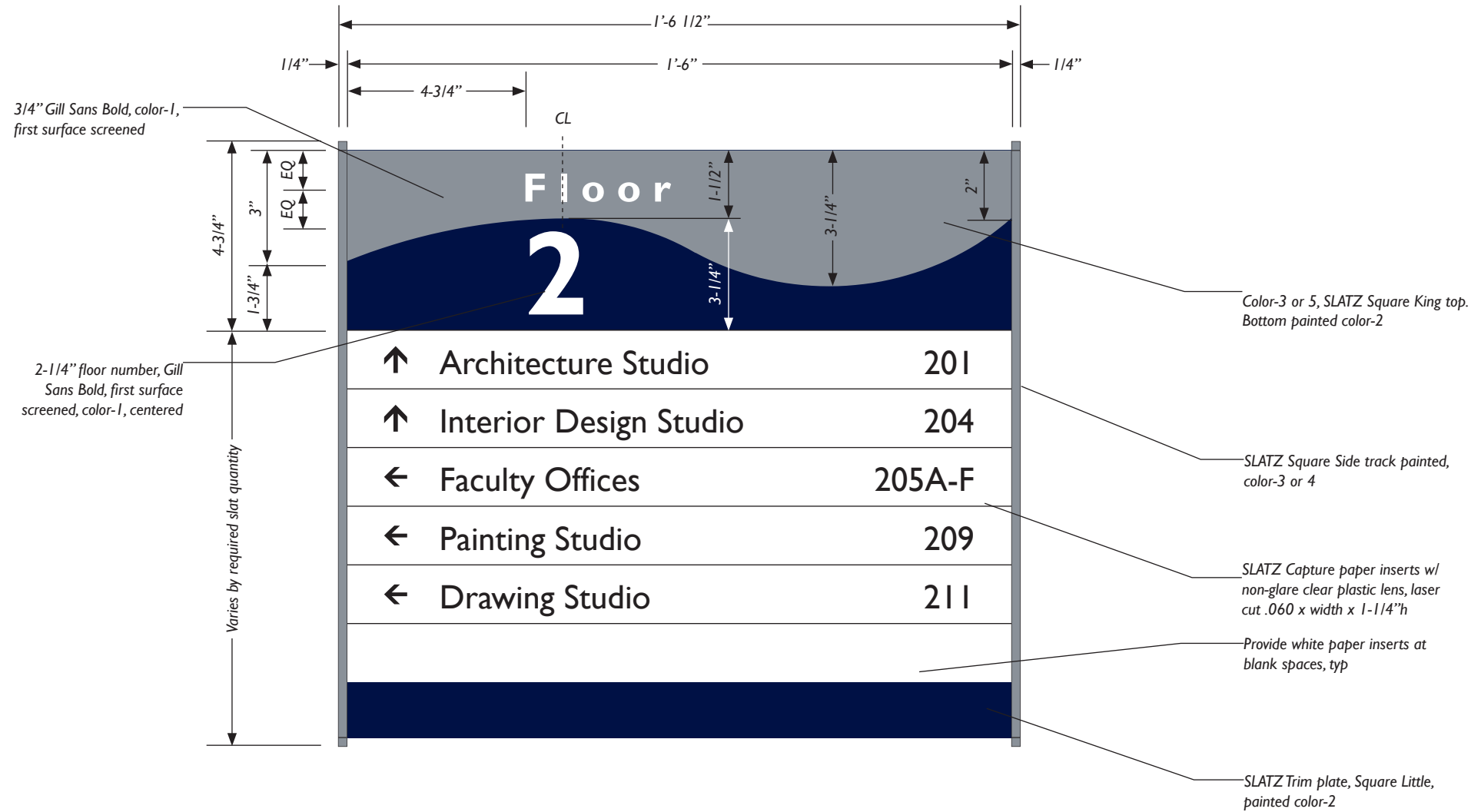
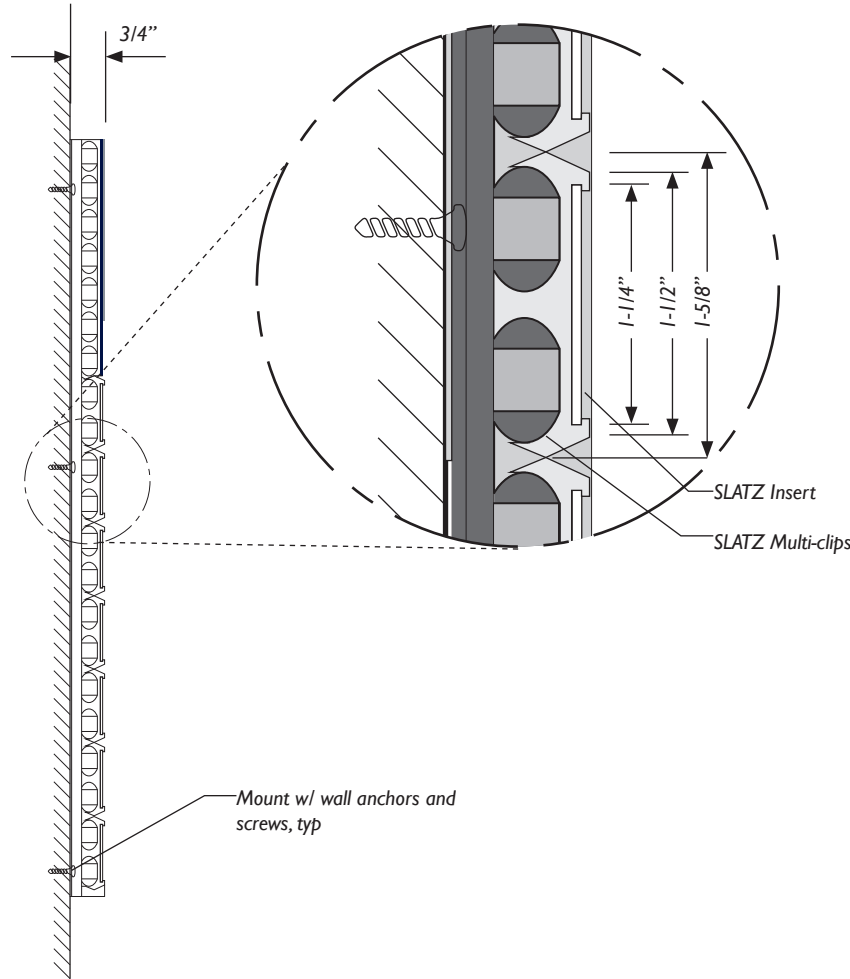

Front Elevation
Scale: 3" = 1'-0"

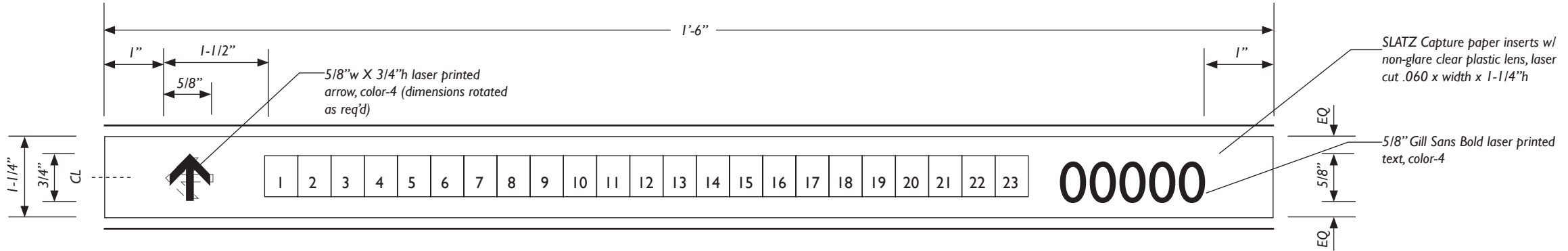

Side Elevation
Scale: 3" = 1'-0"

Insert Detail
Scale: 6" = 1'-0"

Note: Replacement slats for existing directory signage to be SLATZ Little Slatz (faceplate insert) painted Matthews Paint "MSG6425 Satin Hi-Hide White" with first-surface screened font, color-4

Directional Signage

Sign Type D.S: Directional - Block M

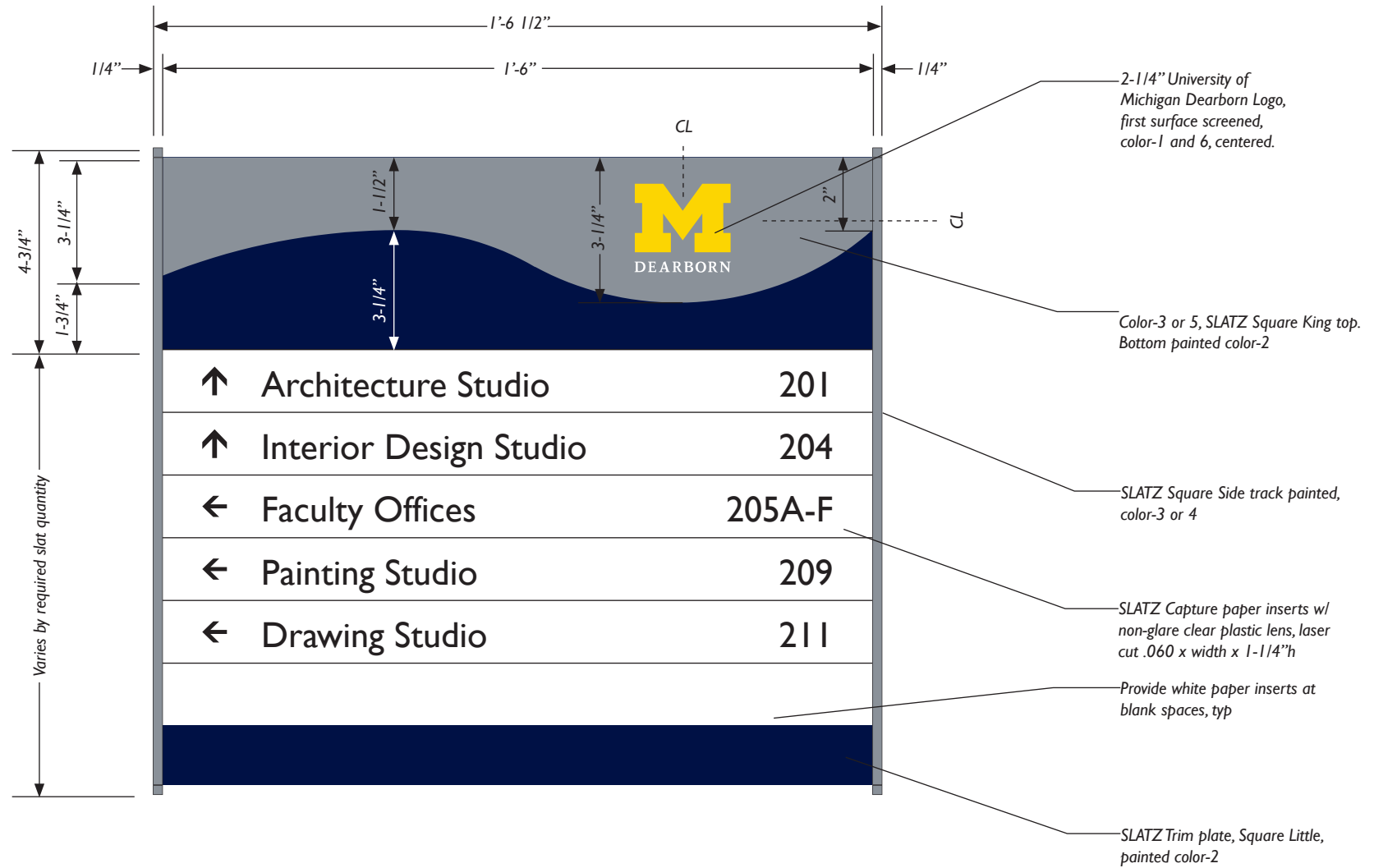
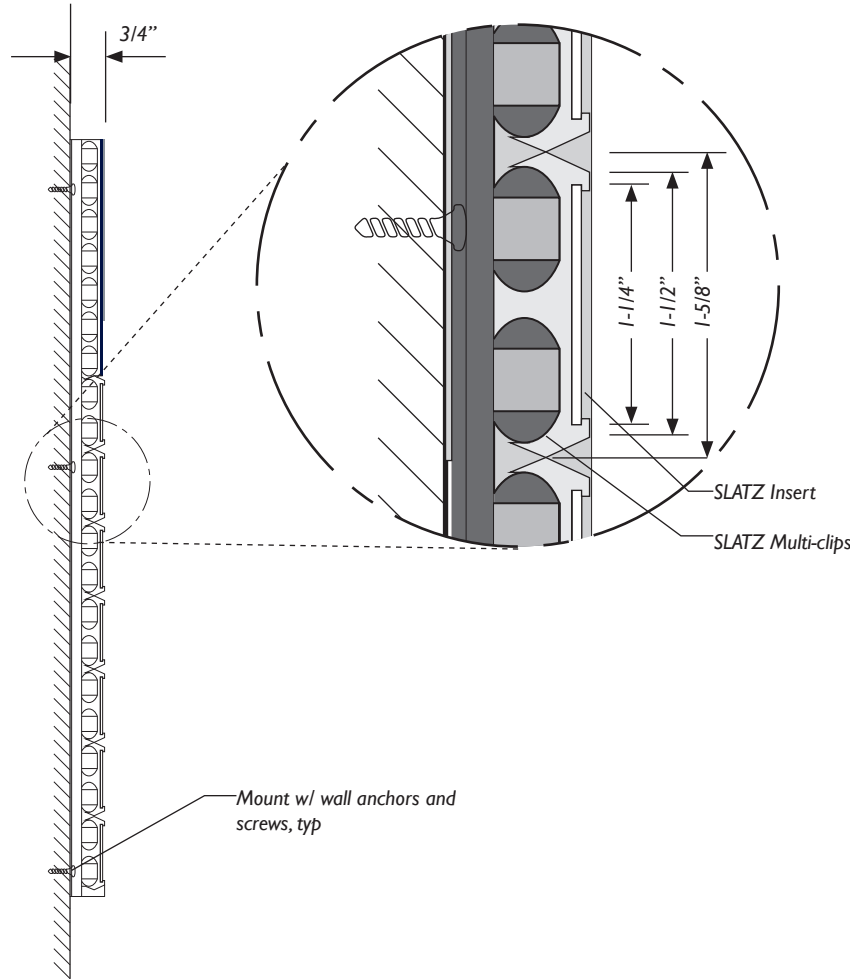

Front Elevation
Scale: 3" = 1'-0"

Side Elevation
Scale: 3" = 1'-0"

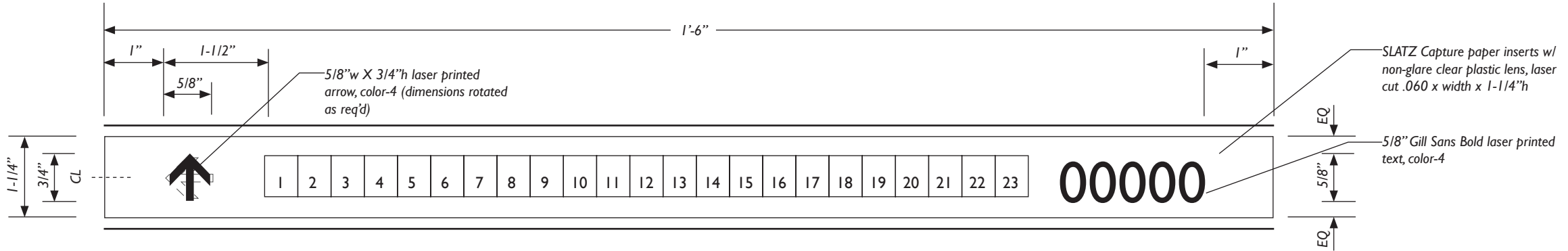

Insert Detail
Scale: 6" = 1'-0"

Note: Replacement slats for existing directory signage to be SLATZ Little Slatz (faceplate insert) painted Matthews Paint "MSG6425 Satin Hi-Hide White" with first-surface screened font, color-4

Directional Signage

Sign Type D1: Directional - Single Unit

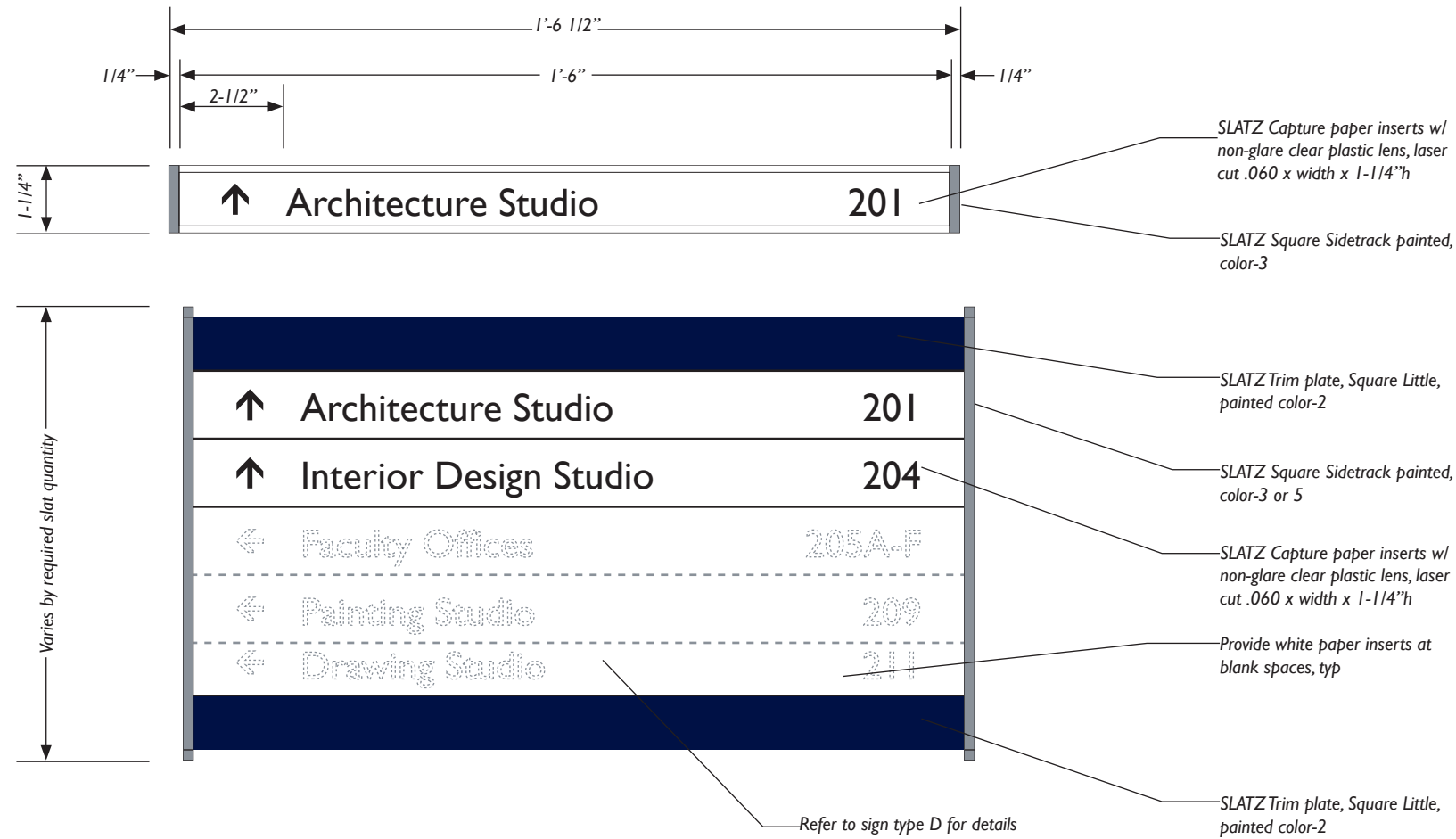

Front Elevation

Scale: 3" = 1'-0"

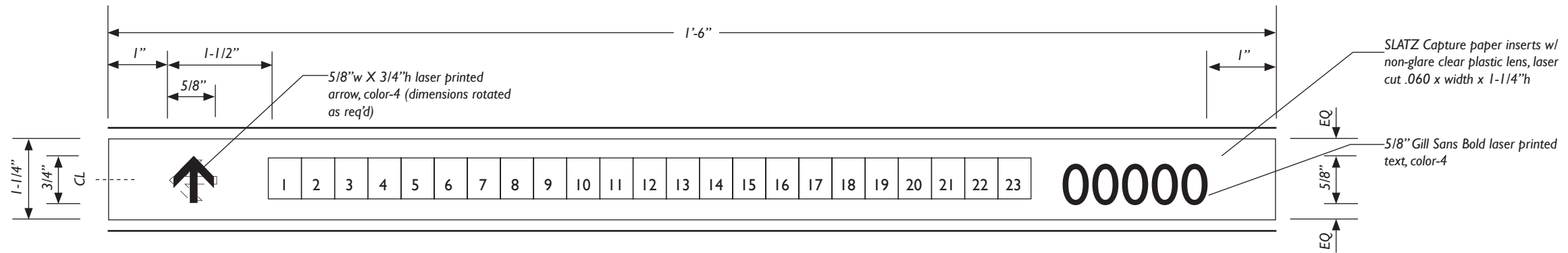

Insert Detail

Scale: 6" = 1'-0"

Note: Replacement slats for existing directory signage to be SLATZ Little Slatz (faceplate insert) painted Matthews Paint "MSG6425 Satin Hi-Hide White" with first-surface screened font, color-4

Directional Signage

Sign Type D1.1: Directional - Single Unit Large

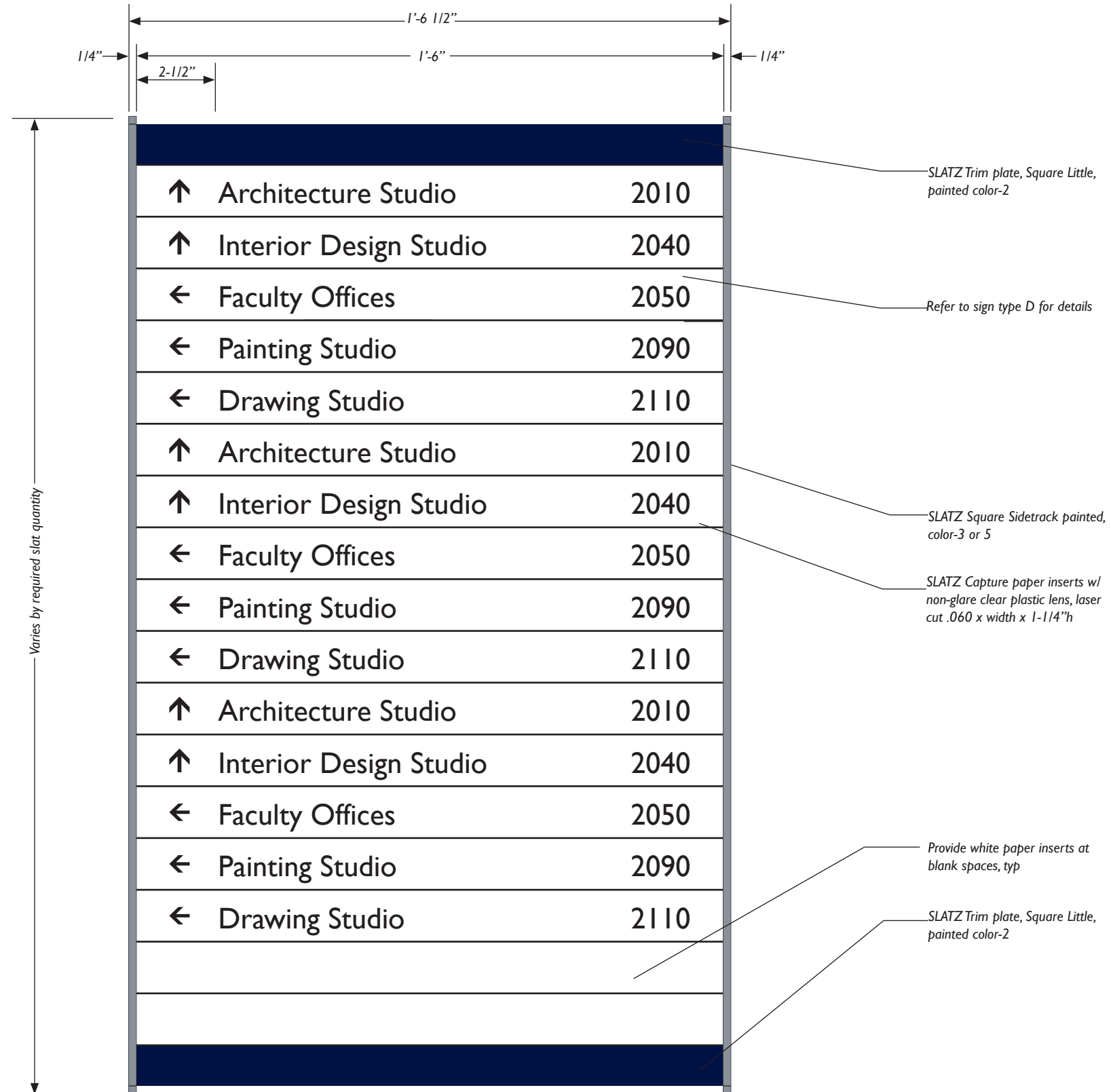

Front Elevation

Scale: 3" = 1'-0"

Note: Replacement slats for existing directory signage to be SLATZ Little Slatz (faceplate insert) painted Matthews Paint "MSG6425 Satin Hi-Hide White" with first-surface screened font, color-4

Orientation Signage

Sign Type E: Directory

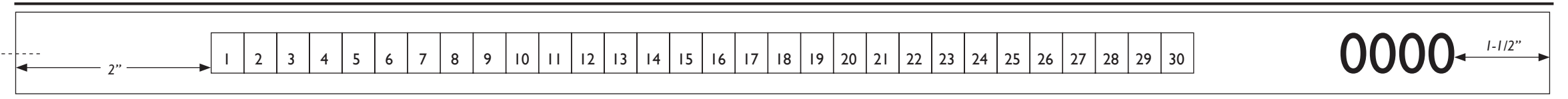
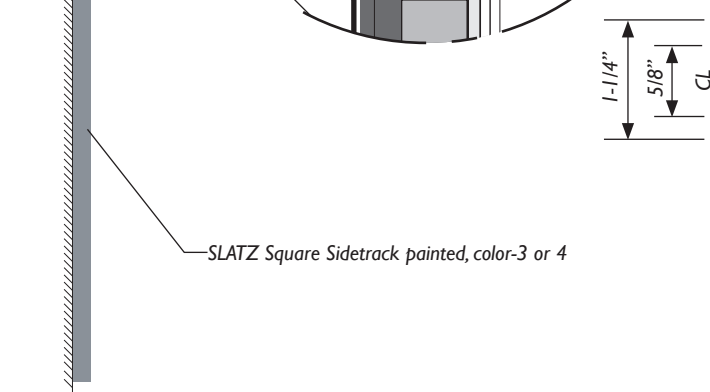
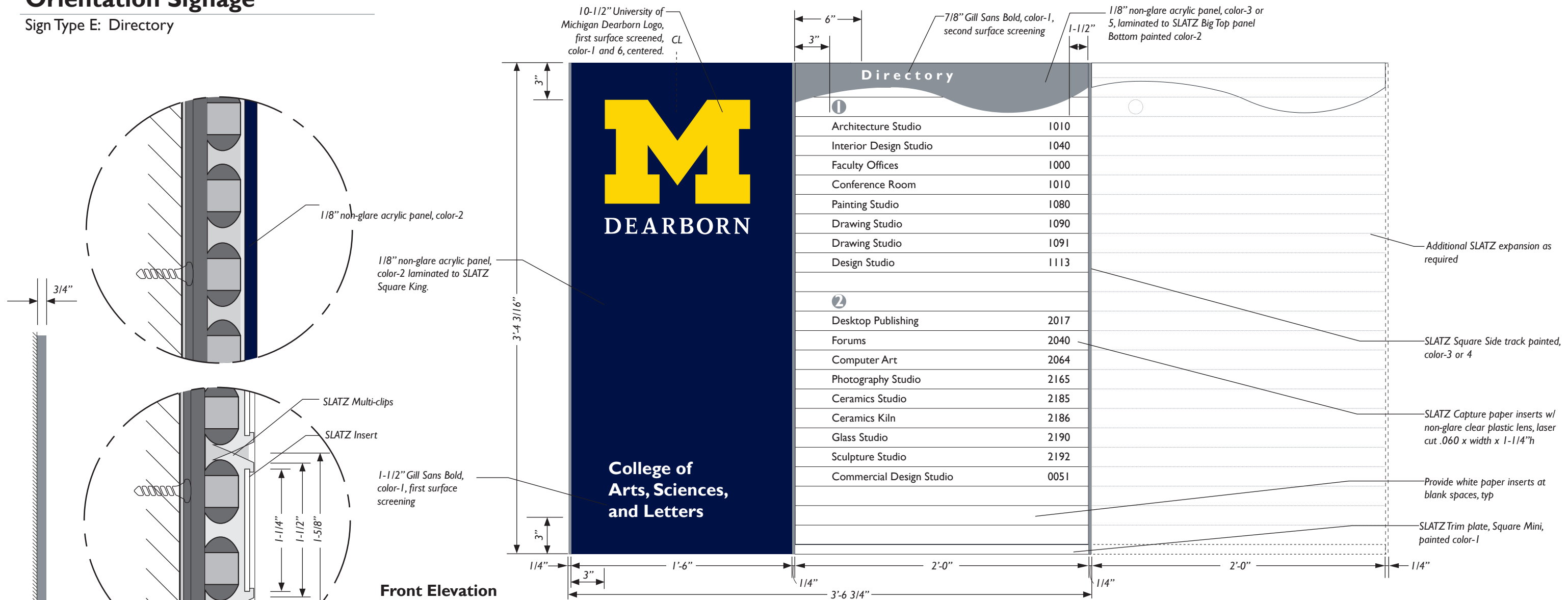

Note: Replacement slats for existing directory signage to be SLATZ Little Slatz (faceplate insert) painted Matthews Paint "MSG6425 Satin Hi-Hide White" with first-surface screened font, color-4

Life Safety Signage

Sign Type F: Stair Identification

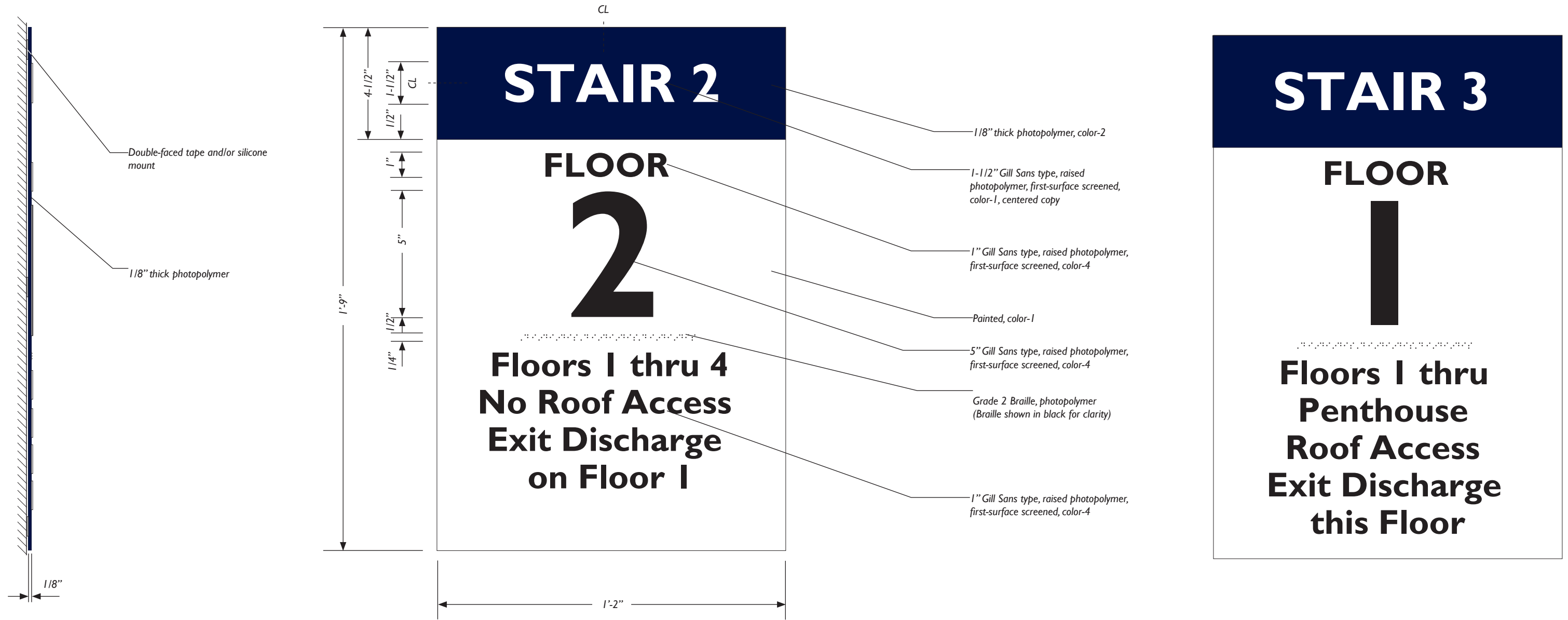

Life Safety Signage

Sign Type H: Occupancy

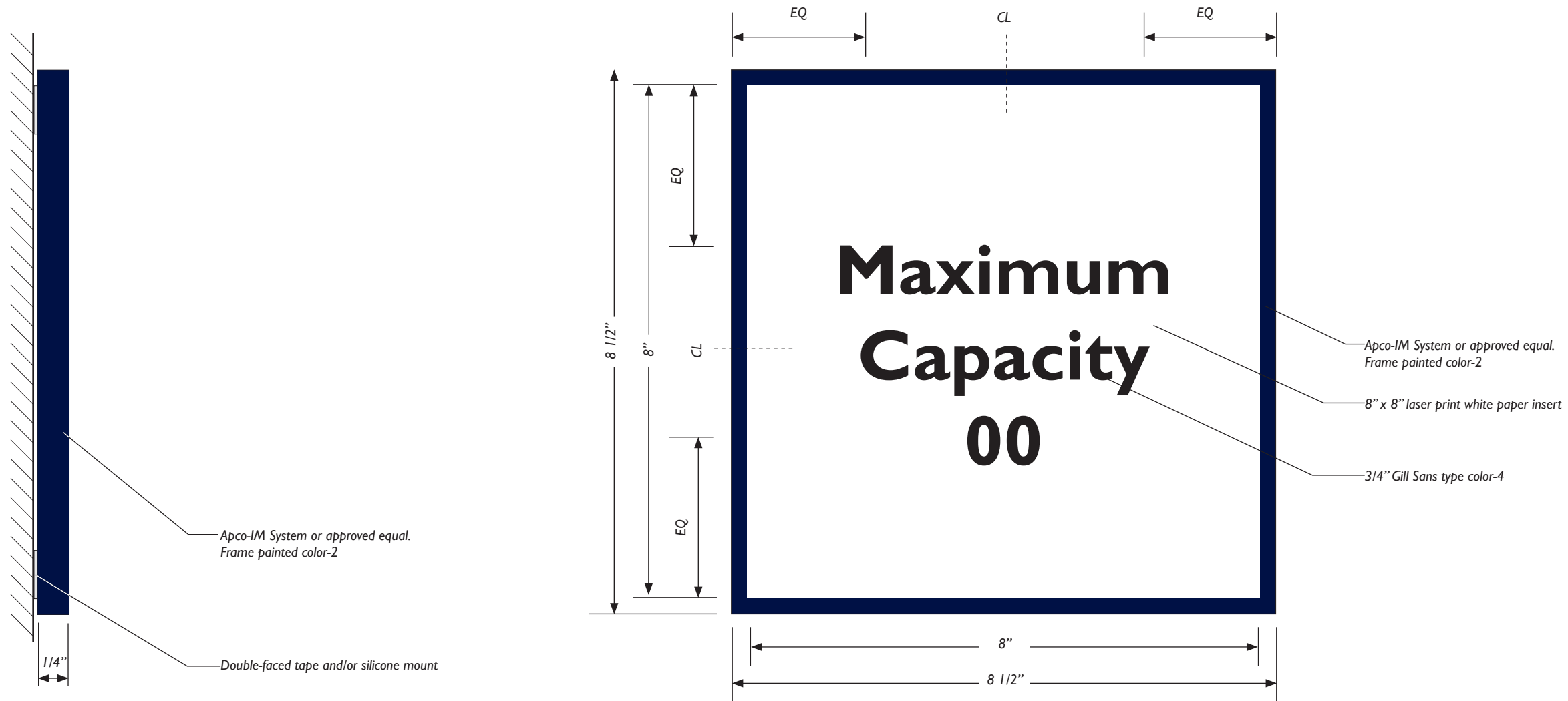

Side Elevation

6" = 1'-0"

Front

Elevation 6" =
1'-0"

Informational Signage

Sign Type I: Campus Phone

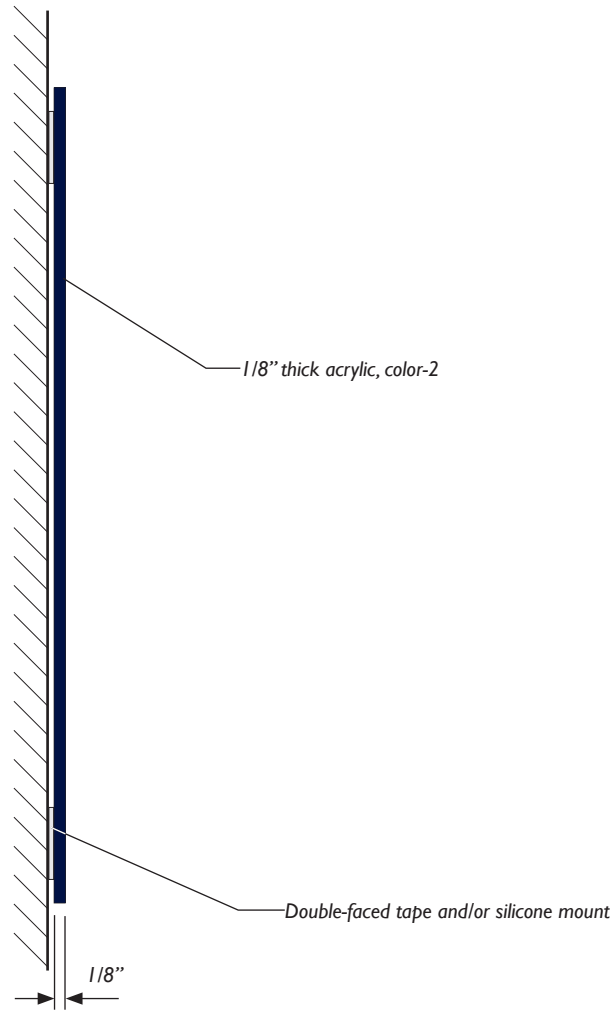

Side Elevation

6" = 1'-0"

Updated December 2020
Interior Sign Standards
Manual Signage Guidelines

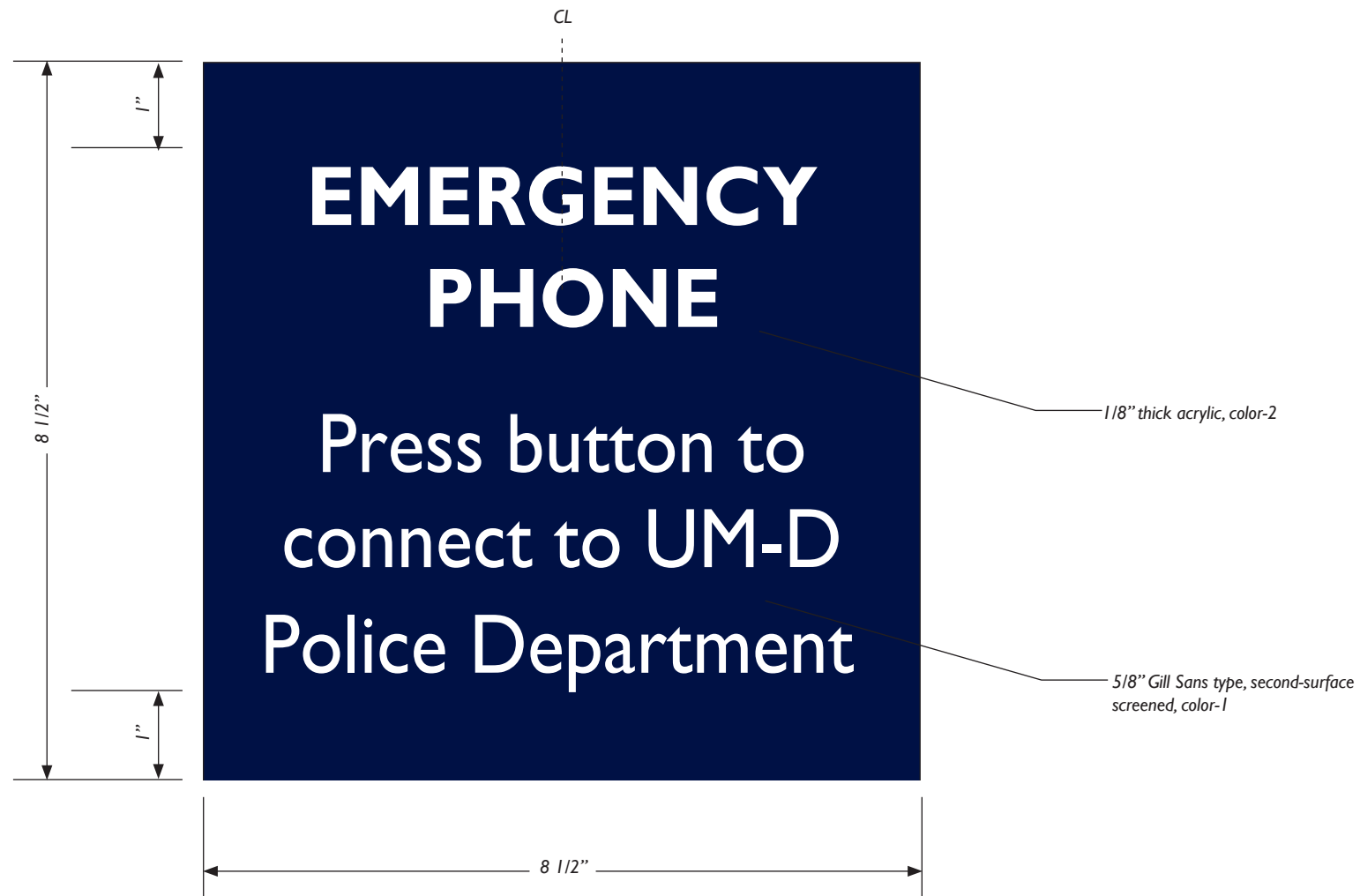

Front

Elevation 6" =

1'-0"

INSTALLATION STANDARDS

Installation standards describe detailed mounting heights and locations in compliance with ADA Guidelines.

Installation Standards

Typical Mounting Locations

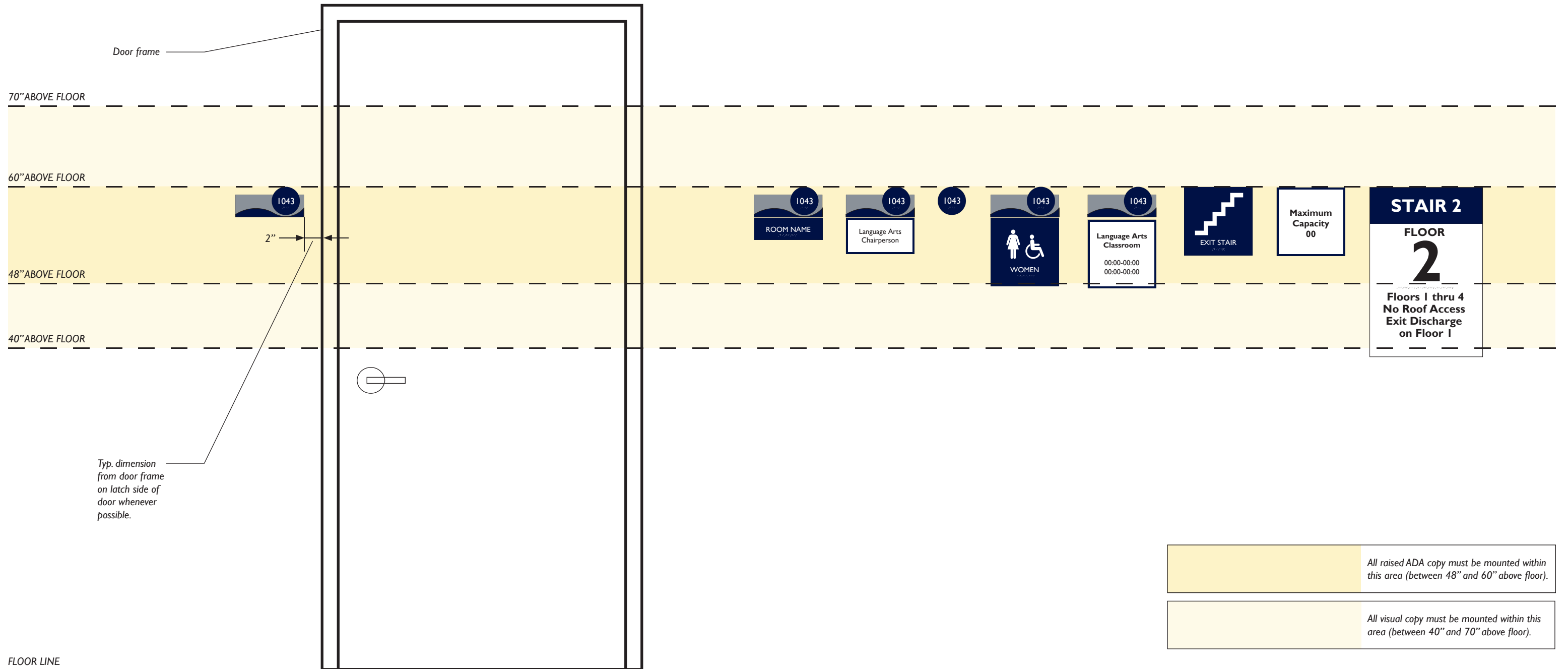

Front Elevation

Scale: 1" = 1'-0"

Installation Standards

Typical Mounting Locations

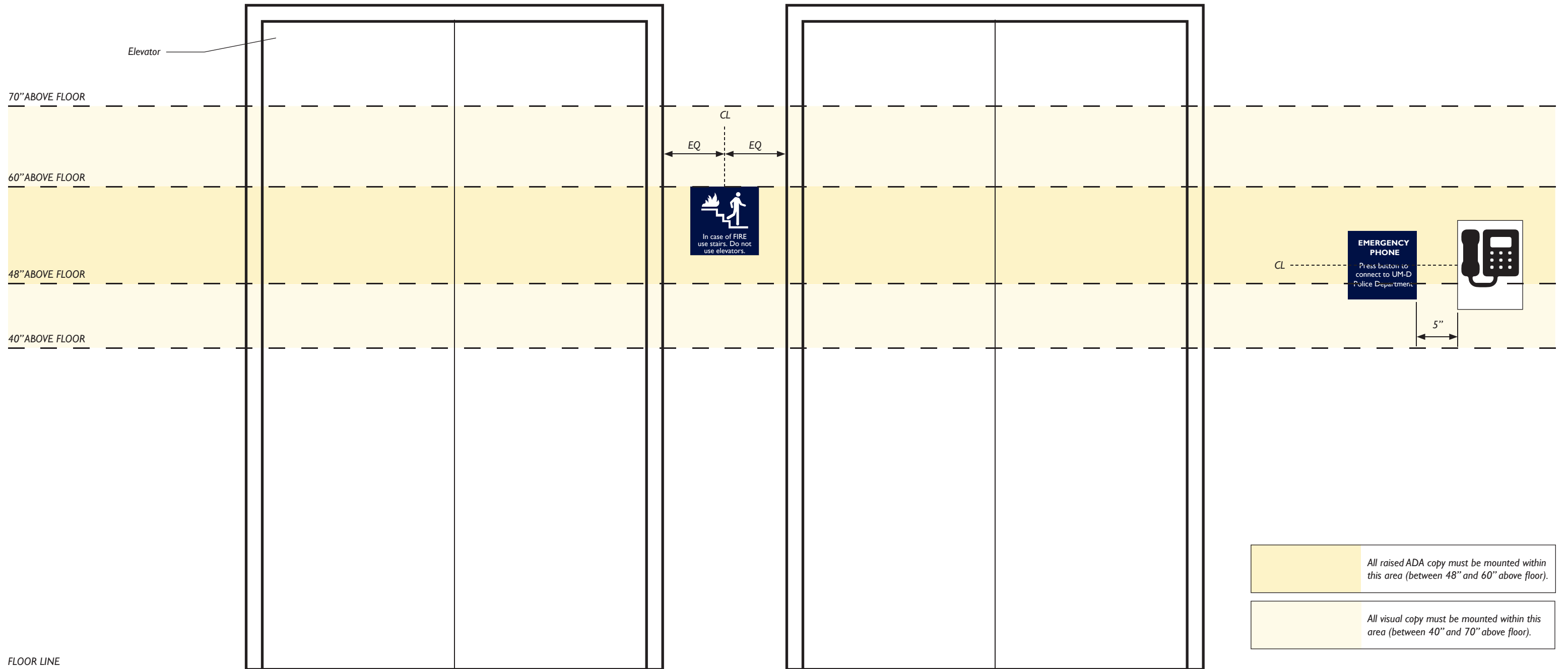

Front

Elevation Scale:

1" = 1'-0"

Installation Standards

Typical Mounting Locations

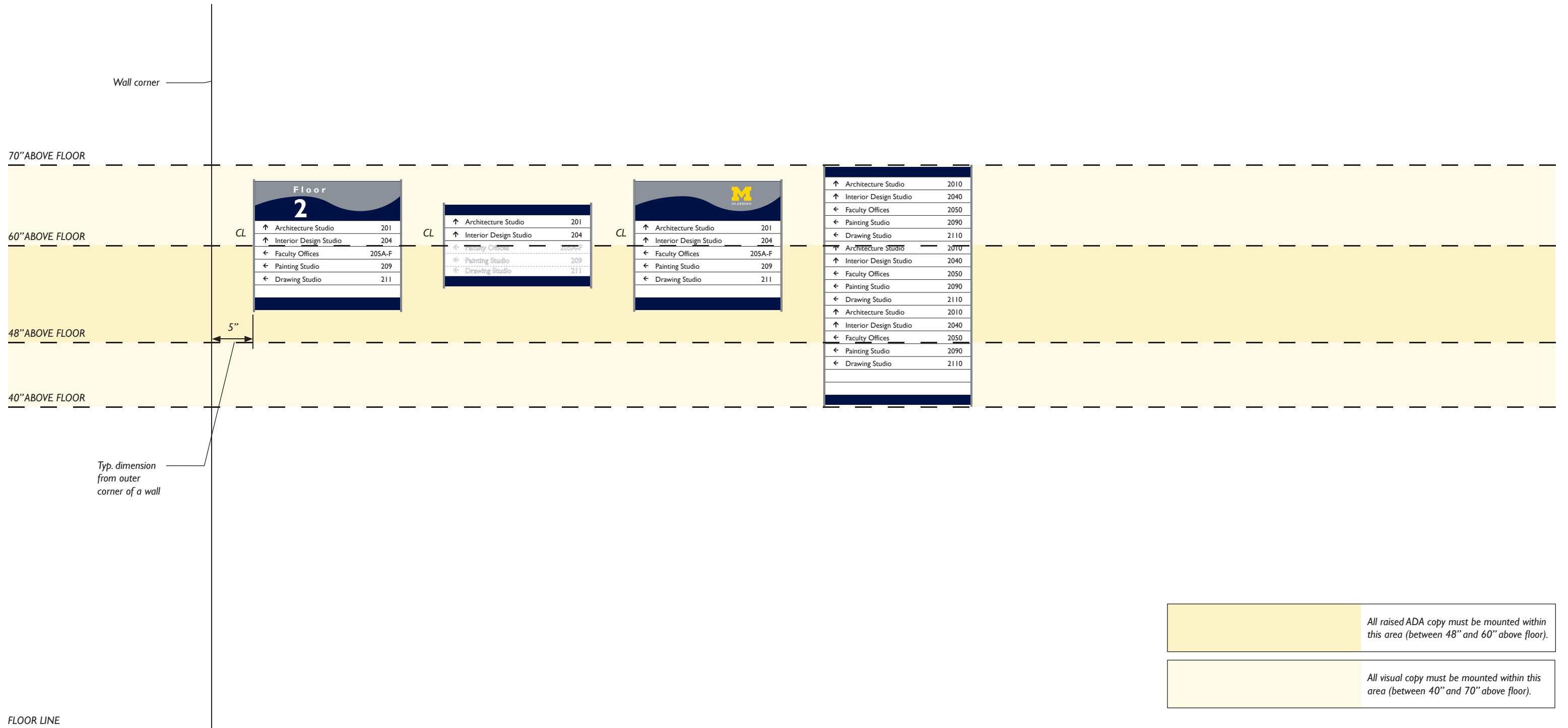

Front

Elevation Scale:

1" = 1'-0"

Installation Standards

Typical Mounting Locations

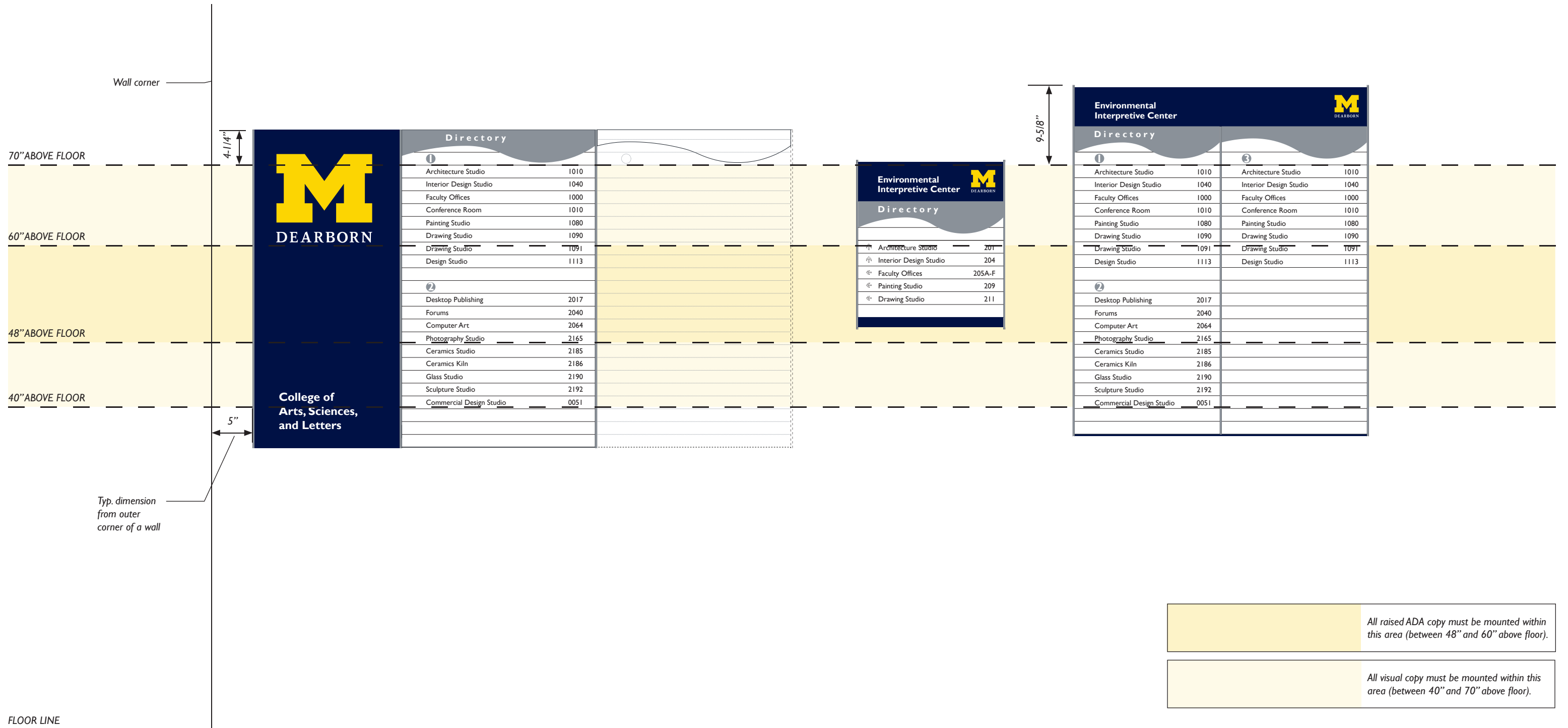

Front

Elevation Scale:

1" = 1'-0"